



(1 Phase 200~240V 0.1~2.2kW)

new

LSLV Micro Drive **M100**

The Best Way
to Save Money and Time

- Built-in C2 EMC Filter
- User-Friendly Design
 - DIN-rail mountable
 - Side-by-side installation
 - Easy connection with RJ45 port
 - Modbus / Smart copier / Remote keypad / DriveView 7
- New UL 61800-5-1 Design
 - Enhanced isolation circuit
- Built-in DB Unit : $\geq 1.5kW$
- Modbus in Advanced I/O Type



Built-in EMC Filter (C2 class)



Side-by-side Installation
(2mm between drives)



DIN-rail Mountable



Smart Copier
(Parameter copy without power)

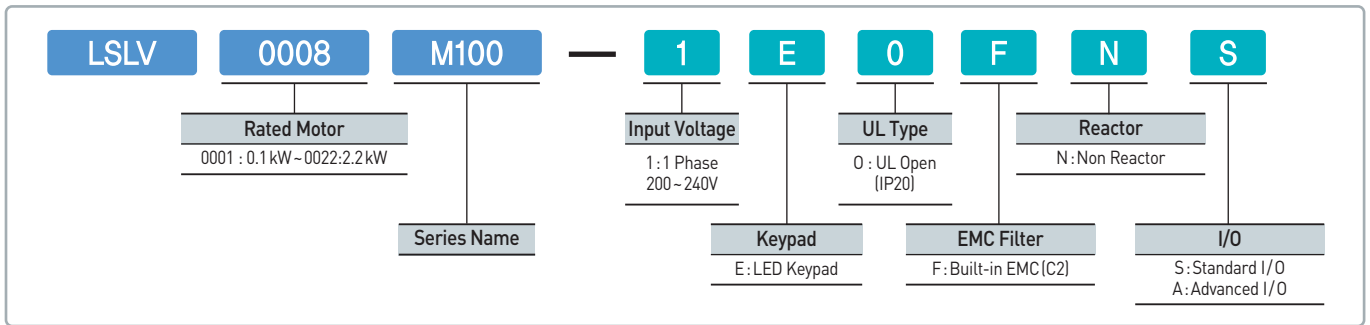

Specification

LSLV□□□□M100-E0FN□		0001	0002	0004	0008	0015	0022	
Applied Motor	Heavy Duty	HP	0.125	0.25	0.5	1.0	2.0	3.0
		kW	0.1	0.2	0.4	0.75	1.5	2.2
Rated Output	Rated Capacity (KVA)		0.3	0.6	0.95	1.9	3.0	4.5
	Rated Current (A)		0.8	1.4	2.4	4.2	7.5	10.0
	Frequency (Hz)		0 ~ 400Hz					
	Voltage (V)		3 phase 200 - 240V					
Rated Input	Rated Current (A)		1.0	1.8	3.7	7.1	13.6	18.7
	Frequency (Hz)		50~60Hz (±5%)					
	Voltage (V)		1 phase 200-240Vac [-15% to +10%]					
Cooling Type		Natural cooling			Forced fan cooling			
Weight (Kg)		0.66			1		1.45	

Environment

Ambient Temperature**	-10~50°C (14~122°F), Ambient temperature under the condition of no ice or frost
Ambient Humidity	Relative humidity less than 95% RH (to avoid condensation forming)
Storage Temperature	-20~65°C (-4~149°F)
Surrounding Environment	Prevent contact with corrosive gases, inflammable gases, oil stains, dust, and other pollutants (Pollution degree 2 environment)
Altitude/Oscillation	Below 1,000m, below 9.8m/sec ² (1G)
Pressure	70~106 kPa

*1) 0.1~0.2kW products can be operated at a maximum of 50°C. However, the lifespan of the product maybe reduced when operating continuously with a full load when the ambient temperature exceeds 40°C

I/O Configuration

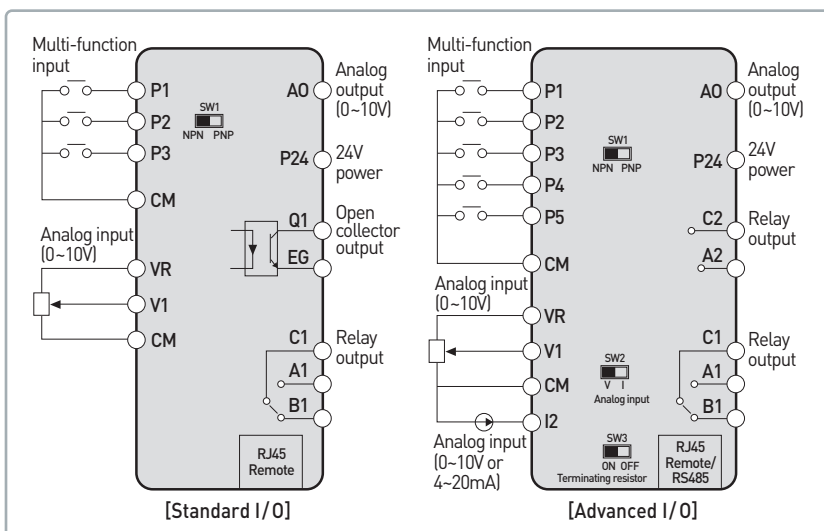

Dimension

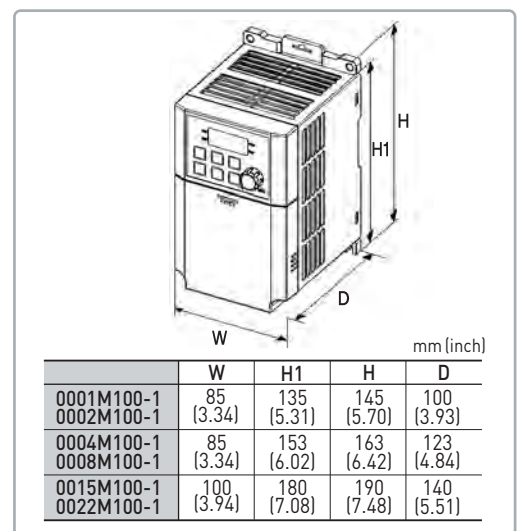

HEAD OFFICE

LS Tower, 127, LS-ro, Dongan-gu, Anyang-si, Gyeonggi-Do, 431-848, Korea
Tel : 82-2-2034-4620 mswoo@lsis.com / Tel : 82-2-2034-4907 hjchoi@lsis.com