

# Pressure Boosting Pumps

## FH6

Closed impellers

60 Hz

### FH603...624

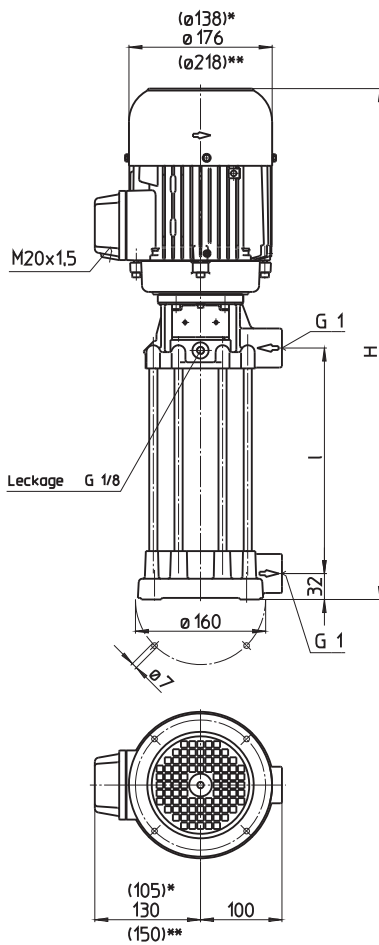

\*) Dimensions for FH603...FH605  
 \*\*) Dimensions for FH612...FH624

| Type     | Vol. del. at manom. del. head<br>l/min / m | Height<br>H mm | Length<br>l mm | Weight<br>kg | Power<br>kW | Voltage<br>3~<br>V | Fre-<br>quen-<br>cy<br>Hz | Current<br>A | Speed<br>1/min |
|----------|--|----------------|----------------|--------------|-------------|--------------------|---------------------------|--------------|----------------|
| FH603B19 | 80/28                                      | 529            | 197            | 19.9         | 0.86        | 460                | 60                        | 1.85         | 3440           |
| FH604B19 | 80/38                                      | 529            | 197            | 21           | 1.06        | 460                | 60                        | 2.1          | 3440           |
| FH605B24 | 80/48                                      | 606            | 247            | 22           | 1.27        | 460                | 60                        | 2.4          | 3440           |
| FH606B24 | 80/58                                      | 628            | 247            | 28           | 1.75        | 460                | 60                        | 3.1          | 3470           |
| FH607B29 | 80/68                                      | 704            | 297            | 32           | 1.95        | 460                | 60                        | 3.5          | 3480           |
| FH608B29 | 80/78                                      | 736            | 297            | 35           | 2.18        | 460                | 60                        | 3.9          | 3500           |
| FH609B34 | 80/88                                      | 786            | 347            | 38           | 2.55        | 460                | 60                        | 4.4          | 3480           |
| FH610B34 | 80/98                                      | 786            | 347            | 39.0         | 2.94        | 460                | 60                        | 5.1          | 3480           |
| FH611B39 | 80/108                                     | 836            | 397            | 39.6         |             |                    |                           |              |                |
| FH612B39 | 80/118                                     | 829            | 397            | 52.3         | 3.45        | 460                | 60                        | 6            | 3520           |
| FH613B49 | 80/128                                     | 929            | 497            | 53.2         | 3.8         | 460                | 60                        | 6.4          | 3520           |
| FH614B49 | 80/139                                     |                |                | 53.5         |             |                    |                           |              |                |
| FH615B49 | 80/149                                     | 929            | 497            | 55.6         | 4.55        | 460                | 60                        | 7.9          | 3520           |
| FH616B49 | 80/159                                     |                |                | 55.8         |             |                    |                           |              |                |
| FH617B59 | 80/168                                     | 1029           | 597            | 56.3         |             |                    |                           |              |                |
| FH618B59 | 80/178                                     | 1059           | 597            | 60.3         | 5.75        | 460                | 60                        | 9.5          | 3520           |
| FH619B59 | 80/188                                     |                |                | 60.4         |             |                    |                           |              |                |
| FH620B59 | 80/198                                     |                |                | 60.5         |             |                    |                           |              |                |
| FH621B69 | 80/206                                     | 1159           | 697            | 61.2         |             |                    |                           |              |                |
| FH622B69 | 80/214                                     |                |                | 61.3         |             |                    |                           |              |                |
| FH623B69 | 80/222                                     | 1159           | 697            | 64.5         | 6.3         | 460                | 60                        | 10.4         | 3510           |
| FH624B69 | 80/232                                     |                |                | 64.7         |             |                    |                           |              |                |

**Pressure Boosting Pumps**

Series TH and FH use **closed impellers** in order to minimize power consumption and to optimize hydraulic pump efficiencies.

In addition, the TH series offers high pressures at short immersion depths. Inline pumps of the series FH can be used as **boosting pumps** if provided with positive inlet pressure. This inlet pressure can be provided by the central coolant supply or a feed pump. In such a setup, pumps of the series FH can raise the incoming pressure by up to 26 bar.

A **frequency converter** can be supplied for **special applications** or for matching the pump characteristic to a specific duty point.

See page "Control/Regulation" in the Technical Information section of this catalog for further information.

**Applications**

- Types of fluid
  - Industry water
  - coolants
  - cooling/cutting oils
- Kinematic viscosity
  - 1 mm<sup>2</sup>/s (1 cSt)
  - higher viscosity upon request
- Pumping temperature
  - 0...80° C

**Construction**

|                    |            |
|--------------------|------------|
| Pump body          | cast iron  |
| Cover              | cast iron  |
| Impellers          | CrNi-steel |
| Shaft              | CrNi-steel |
| Diffusers          | CrNi-steel |
| Mechanical seal    | SiC        |
| O-rings            | Viton      |
| <b>Optional:</b>   |            |
| Pump body          | bronze     |
| Cover              | bronze     |
| <b>Noise level</b> |            |
| FH603...FH605      | 61 dBA     |
| FH606...FH611      | 66 dBA     |
| FH612...FH624      | 75 dBA     |

