

FH14

50 Hz

Closed impellers

FH1402...1417

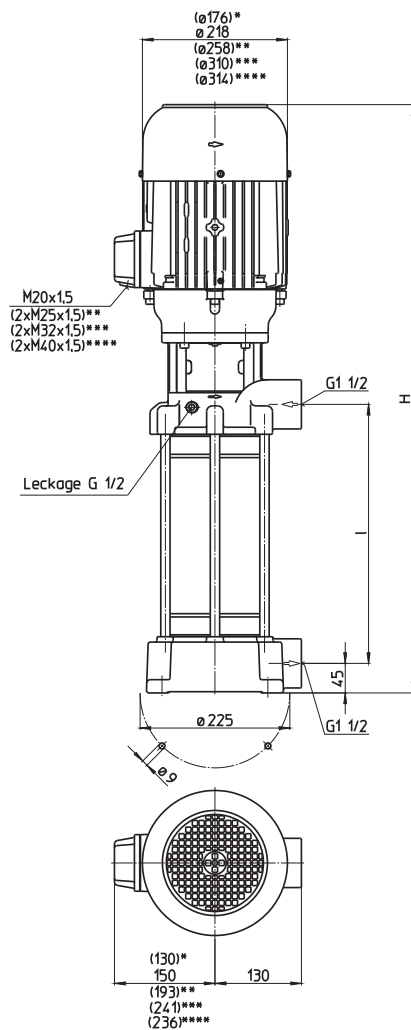

- *) Dimensions for FH1402...1403
- **) Dimensions for FH1408...1411
- ***) Dimensions for FH1412...1416
- ****) Dimensions for FH1417

Type	Vol. del. at manom. del. head l/min / m	Height H mm	Length l mm	Weight kg	Power kW	Voltage 3~ V	Fre- quen- cy Hz	Current A	Speed 1/min
FH1402A18	250/21	669	212	42	1.7	220-240 380-415	50 50	6.24 3.60	2890 2890
FH1403A28	250/38	798	308	49	2.6	220-240 380-415	50 50	9.30 5.35	2880 2880
FH1404A28	250/48	837	308	61	3.3	220-240 380-415	50 50	11.6 6.7	2930 2930
FH1405A38	250/60	933	404	63	4.0	220-240 380-415	50 50	14.50 8.35	2920 2920
FH1406A38	250/74	963	404	69	5.0	220-240 380-415	50 50	17.3 10.0	2920 2920
FH1407A47	250/85	1058	500	72	5.5	220-240 380-415	50 50	18.9 10.9	2915 2915
FH1408A47	250/98	1136	500	103	7.5	380-415	50	14.3	2950
FH1409A57	250/110	1232	596	105					
FH1410A57	250/120	1232	596	112	9.0	380-415	50	16.7	2955
FH1411A66	250/134	1328	692	128					
FH1412A66	250/144	1336	692	137	11.0	380-415	50	20.1	2960
FH1413A76	250/159	1432	788	140					
FH1414A76	250/170	1432	788	144	13.0	380-415	50	24.2	2960
FH1415A90	250/180	1576	932	147					
FH1416A90	250/190			148					
FH1417A90	250/200	1881	932	167	15.0	400	50	27	2960

Pressure Boosting Pumps

series TH and FH use **closed impellers** in order to minimize power consumption and to optimize hydraulic pump efficiencies.

In addition, the TH series offers high pressures at short immersion depths. Inline pumps of the series FH can be used as **boosting pumps** if provided with positive inlet pressure. This inlet pressure can be provided by the central coolant supply or a feed pump. In such a setup, pumps of the series FH can raise the incoming pressure by up to 26 bar.

A **frequency converter** can be supplied for **special applications** or for matching the pump characteristic to a specific duty point.

See page "Control/Regulation" in the Technical Information section of this catalog for further information.

Applications

Types of fluid
 Industry water
 coolants
 cooling/cutting oils
 Kinematic viscosity
 ...25 mm²/s (25 cSt)
 Pumping temperature
 0...80° C

Construction

Pump body	cast iron
Cover	cast iron
Impellers	CrNi-steel
Shaft	CrNi-steel
Diffusers	CrNi-steel
Mechanical seal	SiC
O-rings	Viton

Noise level	
FH1402...FH1403	63 dBA
FH1404...FH1407	71 dBA
FH1408...FH1416	74 dBA
FH1417	78 dBA

