

**HUARE**  
MACHINERY



[www.huare.com](http://www.huare.com)

 **华热机械制造有限公司**  
HUARE MACHINERY MANUFACTURING CO.,LTD.

地址:宁波市北仑小港街道纬九路68号  
Add:No. 68 Wei 9 Road Xiaogang Street Ningbo China  
电话(TEL):+86-574-8615 8788 / 8615 8988  
传真(FAX):+86-574-8615 6666  
E-mail:sales@huare.com  
全国服务热线(Service Hotline China): +400-887 9155

  
**华热机械**  
HUARE MACHINERY



**FOCUS ON RUBBER  
AND PLASTIC  
AUXILIARY MACHINERY  
FOR 20 YEARS**

专注橡塑辅机20年

# Company profile



## 公司简介

宁波华热机械制造有限公司成立于 1998 年，是一家集设计、制造、销售为一体的橡塑辅机高新技术企业。公司处长三角世界级城市群南翼经济中心宁波市，东傍东方大港——宁波港，西接宁波东城快速线，距宁波国际机场仅 30 分钟车程，海陆空区位优势非常明显。现有生产基地 20000 平方米，配有各类先进专业的制造检测设备，是橡塑辅机行业国内品牌的领军企业。

华热公司是国内最早研发及专业化制造橡塑辅机的企业，十几年的奋斗历程使我们拥有自己的品牌“华热”和商标，拥有自主知识产权，并在粉碎撕碎—冷热温控—除湿干燥—输送混合—系统集成等几大产品模块均保持国内企业同步领先的地位。十几个系列上百种产品规格、以及分客户专业化的各式系统配置方案，可满足客户个性化的需求。

而今华热品牌产品早已遍及中国各省市，海外市场也分布到世界各大洲。产品进入从早期的土耳其、埃及、印度、沙特，到后来的西班牙、美国、俄罗斯、巴西等 50 多个国家。在

经济全球化的背景下，感受着世界各新兴市场的经济脉动，华热已将视野及布局拓展至全球。从 2003 年起，公司拥有了自营进出口权，海外业务更是以每年 50% 的平均速度飞速递增。

公司采用信息化管理，配有先进的 CNC 加工中心、激光钣金切割机、CNC 冲床、CNC 车床、环保的油膜漆雾净化室及各类专业的检测设备。公司已通过 CQC ISO9001-2000 认证，瑞士 SGS CE 认证，产品制造严格按照质量管理体系控制。

秉承“诚信、创新、互赢、超越”的企业经营理念，肩负“做中国最好的橡塑辅机”的企业使命，以市场与客户的需求为导向，科学管理，柔性生产，为客户、供方、员工、企业、社会创造更大的价值，致力于成为最具影响力的橡塑辅机行业领军者。

HUARE Machinery Manufacturing Co., Ltd was established in 1998, which is a high-tech enterprise of plastic & rubber auxiliary machinery that combine design, manufacture and sales. Huare Company is located in economic centre of Ningbo, which is the southern of Yangtze River Delta, east is near the Ningbo port, west is connected to Ningbo fast line and it just takes 30 minutes to Ningbo international airport. Now company have a 20,000 M<sup>2</sup> production base, equipped with various kinds of advanced and professional manufacture and testing equipments. Huare is the lead enterprises of domestic brand in plastic & rubber auxiliary machinery field.

HUARE is the earliest company that R&D and professional manufacture of plastic & rubber auxiliary machine. Through more than ten years of struggle that have our own brand HUARE, logo and proprietary independent intellectual property rights. What's more, Huare maintain domestic enterprise synchronous leading status of **granulating & shredding, mold temperature controlling, dehumidifying & drying, material loading & mixing, system integration and etc.** More than a dozen series of hundreds of products specifications, and points of all kinds of customers' professional system configuration scheme of individuation, can meet the customer demand.

Nowadays, HUARE brand products have been all over the domestic and foreign markets. From the products enter Turkey, Egypt, India, Saudi Arabia, to the subsequent Spain, the United States, Russia, Brazil and so on, which is more than 50 countries. From 2003, the company has owned the authority to run self-support export & import rights, and overseas business is increasing rapidly of the average speed by 50% per year.

HUARE adopts information management, equipped with advanced CNC processing center, laser cutting machine, CNC punching, CNC lathe, environmental protection of oil film mist clean rooms and all kinds of professional testing equipment. The company has passed through CQC ISO9001-2000 certification, Switzerland SGS CE certification, and the products manufacturing strictly according to quality management system control.

Adhering to the **"integrity, innovation, mutual win, beyond"** business concept, and shoulder **"do the best plastic & rubber auxiliary machine in China"** corporate mission, according the market and customer demand-driven, scientific management, flexible production. For the customer, supplier, employees, enterprise, society to create greater value, is committed to be the most influential plastic & rubber machine industry leader.



华热公司企业使命：  
做中国最好的橡塑辅机

华热公司经营理念：  
诚信、创新、互赢、超越

华热公司质量方针：  
先进、诚信、服务、改进

# 中央供料系统 CENTRAL FEEDING SYSTEM

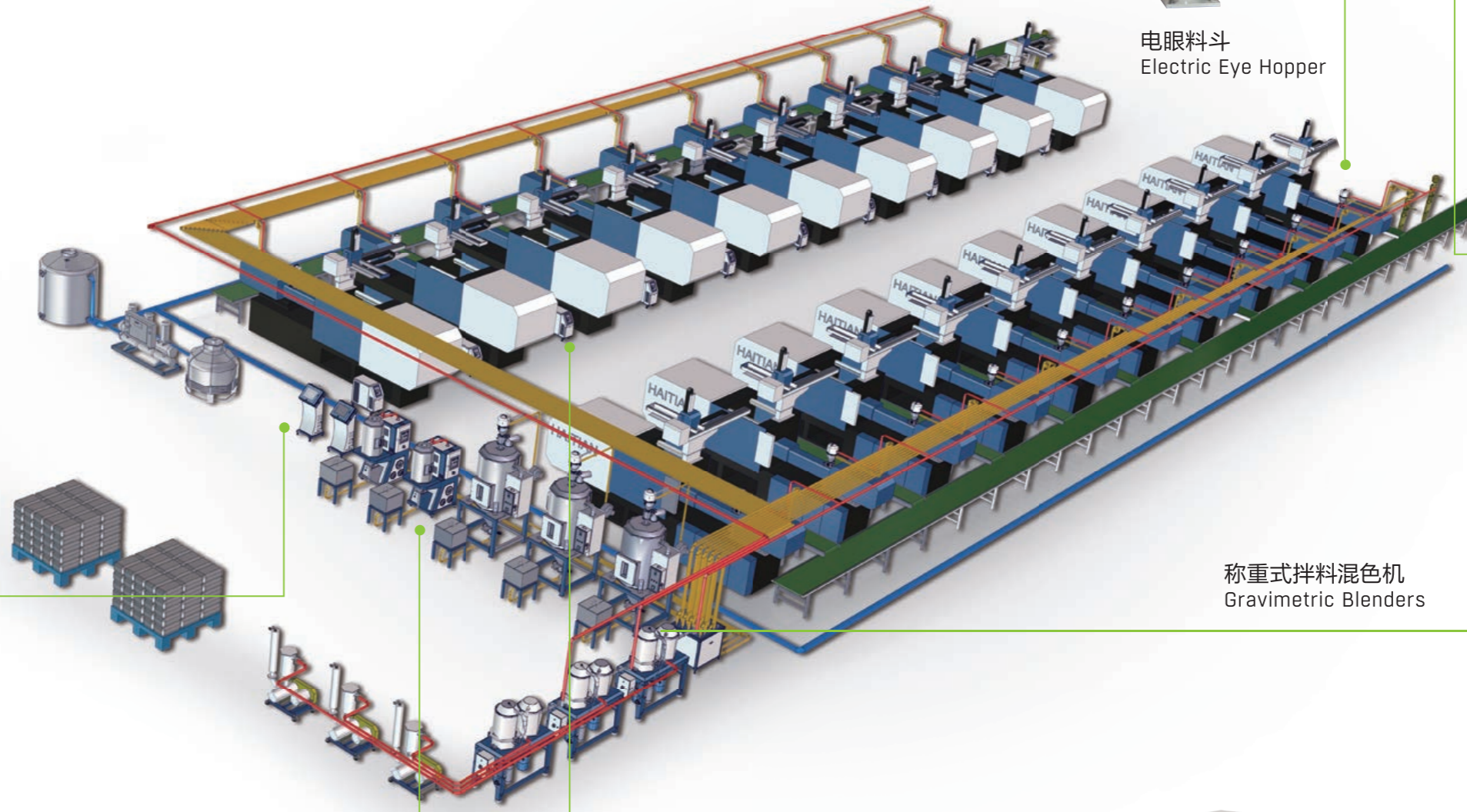

中央控制柜  
Central Control Cabinet

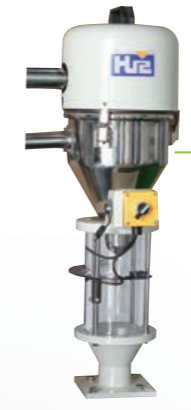

电眼料斗  
Electric Eye Hopper



低速粉碎机  
Low Speed Crusher

称重式拌料混色机  
Gravimetric Blenders



干燥除湿上料组合  
Dehumidified Drying Loader



模具温度控制机  
Mold Temperature Controller



# 中央供料系统 CENTRAL FEEDING SYSTEM

**应用范围**  
该系统主要应用于汽车、家电、日用品、医疗器械、航空、光伏、挤塑/吹塑等重要产业的塑料制造领域。

**Applications**  
The system is mainly used in plastics manufacturing automobiles, home appliances, daily necessities, medical equipment, aerospace, solar and other important industries.

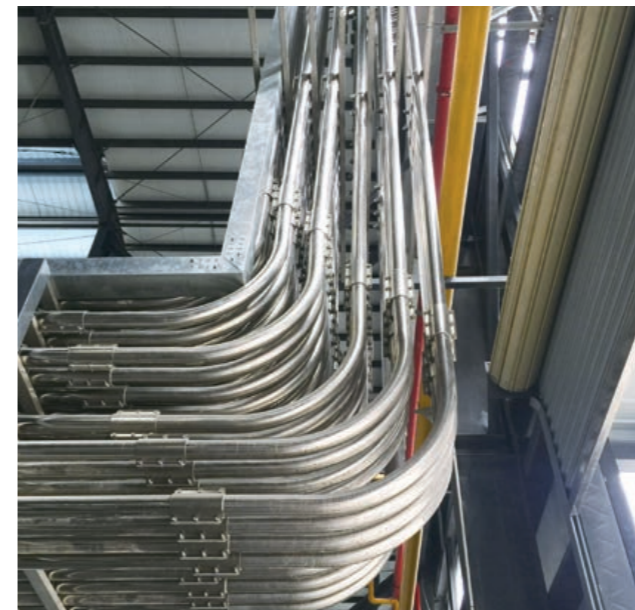

什么是中央供料系统  
What's the central feeding system

实现原料的集中储存处理,并通过封闭的输送系统,以一对多的自动控制器将其多种不同原料按照需求输送至各成型机的一种即节省能源又可降低噪音及污染的全自动化智能操控系统。

Centralized storage processing of raw materials, and by blocking the transport system. In many of the automatic control mode in accordance with the needs of a variety of different raw materials conveyed to each machine. This is the way to save energy and reduce noise and pollution of fully automated intelligent control system

- 优点介绍**
- 设计灵活、耐用、使用周期长;
  - 可同时向多台成型机设备供料,并且系统换料方便快捷;
  - 省电、节约用水;
  - 车间环境改善,不被污染,环境温度降低;
  - 集中管理,减少劳动力;
  - 低能耗,可同时干燥不同原料;
  - 占地面积小,节约空间;
  - 操作简单易学,系统可扩充性,更新费用低,具有成本优势与交期迅速;
  - 产品质量稳定,高产能,安全性高,维修率低,具有多种智能监控及保护功能;
  - 提升现代化企业形象。

- Advantages Introduction**
- Designed to be flexible, durable, long life cycle
  - Simultaneously to multiple machine equipment for the material, and the system is fast and convenient refueling
  - Power, water conservation
  - Can improve the workshop environment, reduce pollution, reduce the ambient temperature
  - Ease of centralized management, reduce labor, save labor
  - Reduce energy consumption, drying different materials at the same time
  - Small footprint, saving space
  - Easy to learn, the system can be expanded, low renewal fees, cost advantage and rapid delivery
  - Stable product quality, high productivity, high security, low maintenance, with a variety of intelligent monitoring and protection functions
  - Enhance the image of the modern enterprise



中央控制柜  
Central control cabinet

中央真空泵组  
Central vacuum pump group

原材料选用站  
Raw materials selection station



中央脉冲过滤器+旋风分离器  
Central pulse filter+ separator cyclone

中央脉冲过滤器  
Central pulse filter

欧化干燥机  
Europeanization hopper dryer

移动集料箱  
Mobile collection bin



系统真空料斗  
Mechanical hopper

系统光电料斗  
Electric eye hopper

截料阀  
Cut-off valve

真空膜片阀  
Vacuum diaphragm valve

真空释压阀  
Vacuum relief valve

承接料斗  
Intermediate hopper

不锈钢接管器  
Stainless steel joint control

管支架  
Tube Supports

玻璃管  
Glass tube

不锈钢快换接头  
Stainless steel quick couplings



华热机械  
HUARE MACHINERY  
中央供料系统  
ENTER

华热机械  
HUARE MACHINERY  
停机中, 请按启动按钮启动系统  
除尘等待 除尘中

吸料  
满料料  
开关  
材料  
截止时间

机边上料 NO.1  
机边上料 NO.2  
机边上料 NO.3  
机边上料 NO.4

二料比例阀

干燥区 注塑区 参照设置 警报查看 说明书 2017.5.4, 16:28:28

1.1、料斗介绍

指示灯: 红色 绿色 蓝色  
满料料 未吸料报警 料满  
开关 关闭 打开

原料来源 显示料来源  
料斗序号 显示料斗序号  
截止时间 显示截止时间

干燥区 注塑区 参照设置 警报查看 说明书 2017.5.4, 16:28:28

1.2、监视界面介绍

- 1 除尘等待, 除尘指示灯, 以及报警指示
- 2 正在吸料的料斗, 料斗满载, 洗料剩余时间, 料斗剩余时间
- 3 吸力方向
- 4 风机转动指示
- 5 界面切换

干燥区 注塑区 参照设置 警报查看 说明书 2017.5.4, 16:28:28



HDL-80F

# HDL

## HDL干燥除湿上料组合 DEHUMIDIFYING & DRYING SERIES

可提供-40° 低露点干燥风, 集成除湿、干燥、送料功能于一体,  
外形美观大方, 结构简单合理, 方便保养;  
适用于吸湿性很强的工程塑料如: PA、PC、PBT、PET、ABS等

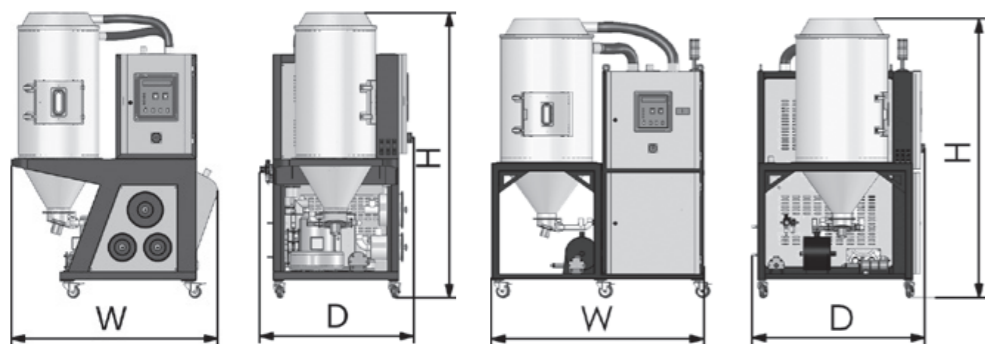
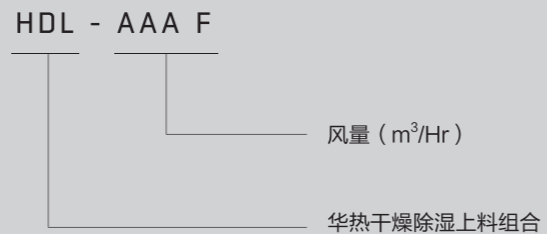

50F-120F

200F-1000F



HDL-400F

## 规格表 Specifications

机 型	Type		HDL-50F	HDL-80F	HDL-120F	HDL-200F	HDL-300F	HDL-400F	HDL-600F	HDL-1000F
保温桶容量	Drying hopper capacity	L	80	120	160	320	540	660	900	1500
除湿风量	Dry air capacity	m <sup>3</sup> /hr	50	80	120	200	300	400	600	1000
干燥电热功率	Heater power	kW	3	6	7.5	10.5	15	18	25	32
干燥风机功率	Blower power	kW	0.4	0.7	0.85	1.6	2.2	4	5.5	9
再生电热功率	Regen heater power	kW	3	4.5	4.5	6	7.5	7.5	10	15
再生风机功率	Regen blower power	kW	0.2	0.2	0.2	0.4	0.55	0.7	1.6	1.6
送料风机功率	Transporting blower power	kW	1.3	1.3	1.3	2.2	2.2	2.2	2.2	2.2
吸料机配管	Pipe diameter	Inch	1.5	1.5	1.5	1.5	1.5	1.5	2	2
外形尺寸	Dimensions									
H		mm	1700	1700	1770	2080	2170	2460	2700	3200
W		mm	1285	1285	1315	1280	1280	1280	1390	1700
D		mm	880	880	920	1575	1710	1710	2200	2550

### 特点

- 该系列采用PID温度控制系统, 可精确控制干燥与再生温度;
- 全不锈钢双层保温式料桶采用下吹风管设计, 能防止热能散失, 确保干燥温度, 提高干燥效率;
- 全封闭式送料系统, 可避免干燥后的原料回潮;
- 具有超温保护、马达过载、逆相保护等报警保护与功能;
- 集除湿、干燥、二段送料于一体, 客户可根据实际用途选择一对一、一对二、二对一送料功能的机型。

### 选配项目

- 三段送料一对二功能可选配;
- 露点仪可选配;
- HLINK联网功能可选配
- Three- section feed 1 TO 2 function can be optional
- Dew Point Meter can be optional
- HLINK networking function can be optional

### 注意事项:

- 机器标准电压规格为: 3Φ 380V 50Hz。
- 客户如需定制特殊规格, 请与本公司联系确认。
- 产品规格若有变更, 恕不另行通知。

### Note:

- Standard voltage: 3 Phase 380V 50 Hz;
- Have any special needs, please contact us.
- Specifications are subject to change without prior notice.

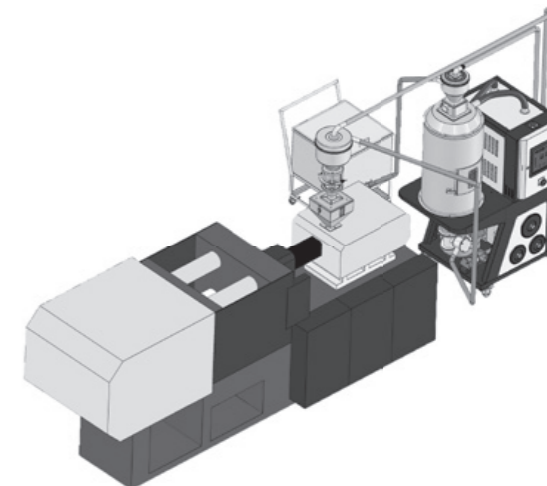

一对一成型机安装例图  
Example of one to one installation diagram

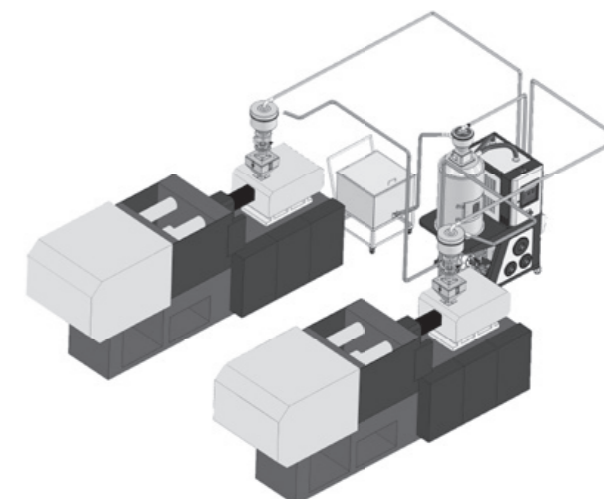

一对二成型机安装例图  
Example of one to two installation diagram



HD-400F

**HD**

## HD蜂巢除湿机 HONEYCOMB DEHUMIDIFIER

可提供-40° 低露点干燥风，外观美观大方，结构简单合理，方便保养；

适用于吸湿性很强的工程塑料如：PA、PC、PBT、PET、ABS等；

HD - AAA F

风量 (m<sup>3</sup>/Hr)

华热蜂巢除湿机

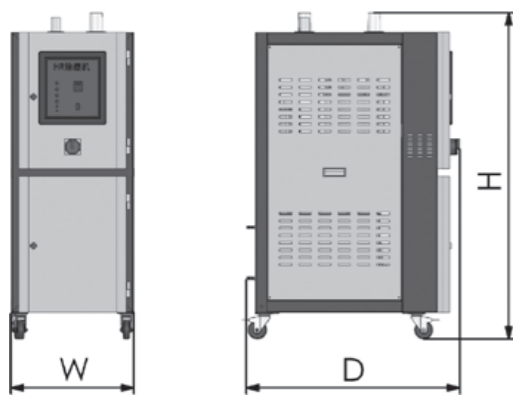

### 特点

- 该系列采用PID温度控制系统，可精确控制再生温度；
- 具有超温保护、马达过载、逆相保护等报警保护与功能；
- 内部装有回风过滤器，确保蜂巢转轮不受原料粉尘污染。

### Special Features

- This series adopt PID temperature control system, can precisely control regeneration temperature;
- With over temperature protection, motor overload, reverse protection alarming protective function;
- The inner is equipped with return air filter, ensure runner from raw material hives dust pollution.

## 规格表 Specifications

机 型	Type		HD-50F	HD-80F	HD-120F	HD-200F	HD-300F	HD-400F	HD-600F	HD-800F	HD-1000F
除湿风量	Dry air capacity	m <sup>3</sup> /hr	50	80	120	200	300	400	600	800	1000
再生电热功率	Regen heater power	kW	3	4.5	4.5	6	7.5	7.5	10	12.5	15
干燥风机功率	Blower power	kW	0.4	0.7	0.85	1.6	2.2	4	5.5	7.5	9
再生风机功率	Regen blower power	kW	0.2	0.2	0.2	0.4	0.7	0.7	1.6	1.6	2.2
通风管径	Pipe diameter	inch	2	2	2	3	3	3	4	5	5
最低露点	Lowest dew point	°C	-40	-40	-40	-40	-40	-40	-40	-40	-40
外形尺寸											
Dimensions											
H		mm	1340	1490	1490	1700	1800	1800	2100	2230	2230
W		mm	500	500	500	750	750	750	1060	1120	1310
D		mm	875	875	875	1280	1280	1280	1390	1510	1510

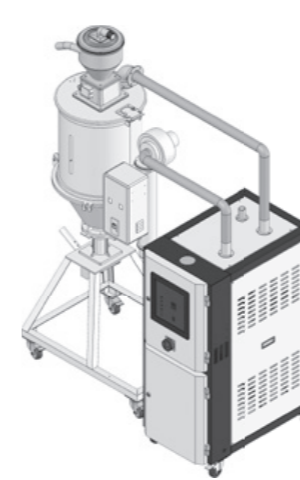

一对一成型机安装例图  
Example of one to one installation diagram

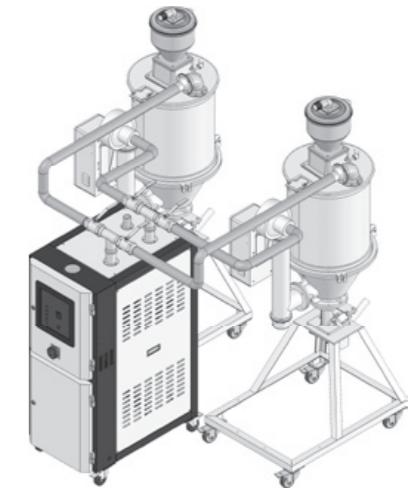

一对二成型机安装例图  
Example of one to two installation diagram

### 选配项目

- 一对二主机功能可选配；
- 露点仪可选配；

### 注意事项:

- 订购时需提供需联接热风管长度；
- 配套外司干燥机时需提供风机进风盖与弯头出风口安装尺寸；
- 机器标准电压规格为：3Φ 380V 50Hz。
- 客户如需定制特殊规格，请与本公司联系确认。
- 产品规格若有变更，恕不另行通知

### Optional

- 1 TO 2 master machine function can be optional
- Dew Point Meter can be optional

### Note:

- Please provide the length of the air hose to be connected when ordering.
- Please provide the fan inlet and elbow outlet installation dimensions when supporting other companies' dryer.
- Standard voltage: 3 Phase 380V 50 Hz;
- Have any special needs, please contact us.
- Specifications are subject to change without prior notice.



HHD-50E



E

ET

# HHD

## HHD料斗干燥机 HOPPER DRYER

HHD系列料斗干燥机是干燥塑胶原料最有效且最经济的机型，可以干燥因包装、运送或回收而潮湿的原料。直结式的设计特点适合于直接安装在塑胶成型机上进行干燥，既快速又节省空间。这种上吹式的热风干燥机能提供的装料量为12~1,000公斤。

HHD - AAA - BBB

- EM= 磁力底座
- ET=24 小时定时器
- ETM=24 小时定时器 + 磁力底座
- HHD-300E 及以上标配为 ET 机型
- 装料量 (Kg)
- 华热料斗干燥机

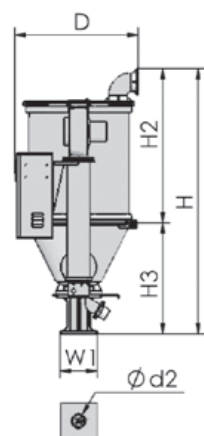

12E-400E

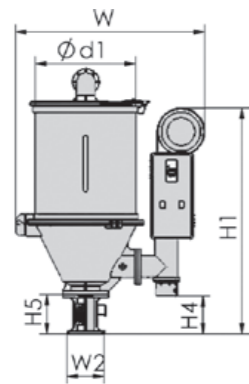

600E-1000E

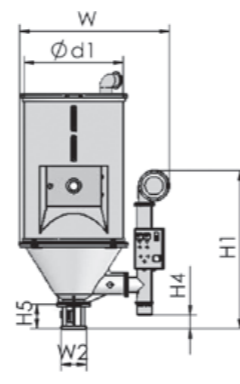
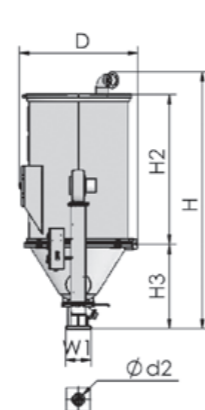

## 规格表 Specifications

型号	单位	HHD-12E	HHD-25E	HHD-50E	HHD-75E	HHD-100E	HHD-150E
装料量	kg	12	25	50	75	100	150
电热功率	kW	2.1	2.7	3.9	5	7.8	8.9
送风机功率	kW	0.14	0.14	0.17	0.17	0.35	0.35
重量	kg	31	36	53	56	85	118
H	mm	820	990	1145	1320	1410	1500
H1	mm	750	860	1035	1044	1215	1210
H2	mm	370	460	520	680	730	780
H3	mm	325	410	480	490	540	570
H4	mm	50	120	160	165	135	130
H5	mm	110	160	170	170	170	170
Φd	mm	375	425	535	545	595	650
Φd1	mm	300	350	435	470	550	530
Φd2	mm	48	63	63	63	92	92
W	mm	630	685	820	860	1050	1140
W1	mm	110	150	160	160	220	220
W2	mm	110	150	160	160	220	220

型号	单位	HHD-200E	HHD-300E	HHD-400E	HHD-600E	HHD-800E	HHD-1000E
装料量	kg	200	300	400	600	800	1000
电热功率	kW	10	15	20	27	32	32
送风机功率	kW	0.75	0.75	0.75	0.75	1	1
重量	kg	155	215	265	300	320	340
H	mm	1685	1855	1995	2290	2665	2830
H1	mm	1265	1545	1560	1705	1705	1950
H2	mm	825	935	1030	1270	1650	1650
H3	mm	610	675	710	765	765	950
H4	mm	140	105	120	120	120	150
H5	mm	210	210	210	255	255	270
Φd	mm	760	915	1000	1160	1160	1310
Φd1	mm	700	760	835	995	995	1095
Φd2	mm	105	110	120	135	135	135
W	mm	1170	1290	1385	1585	1580	1665
W1	mm	240	320	320	320	320	320
W2	mm	240	320	320	320	320	320

### 特点

- 外观新颖，外表光亮；
- 热风分布均匀，增加干燥效率；
- 全数位式P.I.D控制；
- 料桶及内部零件一律采用不锈钢制；
- 料桶与底部分离，清料方便，换料迅速；
- 过热保护装置，可减少人为或机械故障所产生之意外；
- 标配主电源开关&超温脱扣保护(ET机型)；

### 选配项目

- 可选配排风空气滤清器、风机入口过滤器、磁力底座、磁力架、热风回收器、地上支架、移动集料箱、吸料盒等附件；
- 双层保温功能可选配；
- HLINK联网功能可选配；

### 注意事项：

- 加装24小时定时器，机型后加注“T”。
- 加装磁力底座，机型后加注“M”。
- 以上装料量是以颗粒直径3-5mm，堆积密度约0.65kg/L的标准塑料原料折算。
- 电源必须使用规定电压。
- 客户如需定制特殊规格，请与本公司联系确认。
- 产品规格若有变更，恕不另行通知

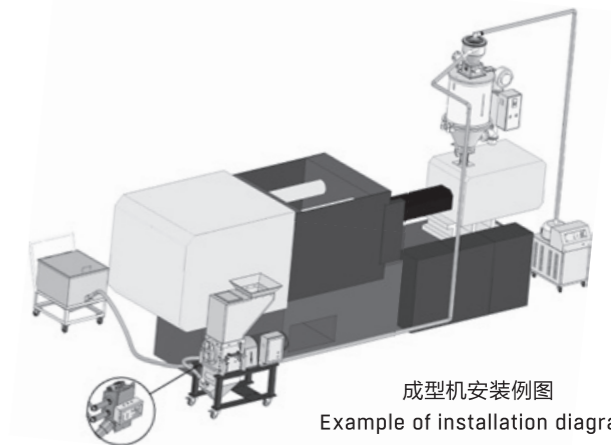

成型机安装例图  
Example of installation diagram

- Exhaust Air Filter/Fan Inlet Filter/Magnetic Base/Magnetic Frame/Hot Air Recycling/Ground Frame/Mobile Collection Bin/Suction Box and other accessories can be optional
- Double-layer insulation cylinder function can be optional
- HLINK networking function can be optional

### Note:

- Add 24-hour timer, the model after filling "T".
- Add magnetic base, the model after filling "M".
- The above loading is based on the particle diameter of 3-5mm, the bulk density of about 0.65kg / L standard plastic raw materials conversion.
- The power supply must use the specified voltage.
- Have any special needs, please contact us.
- Specifications are subject to change without prior notice.





**HLD-50E-600GN**

# HLD

## HLD 干燥上料组合 HOPPER DRYER & AUTO-LOADER

HLD干燥上料组合是将干燥机与上料机通过L型支架组合连接，并配备吸料盒，备有脚轮便于移动，干燥与上料功能组合一体，方便客户直接使用。

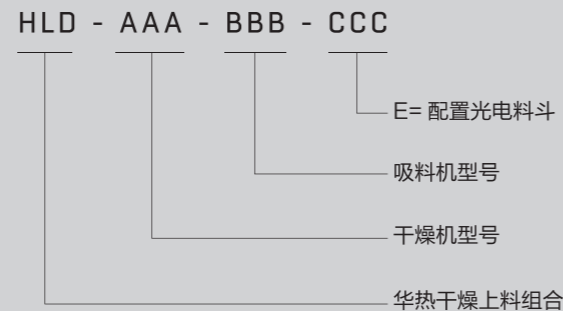

6升真空料斗 / MH-6L  
6L Mechanical hopper



6升光电料斗 / PH-6L  
6 L Photoelectric hopper

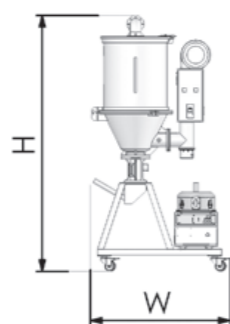

HLD-25E-300GN - HLD-200ET-800GND

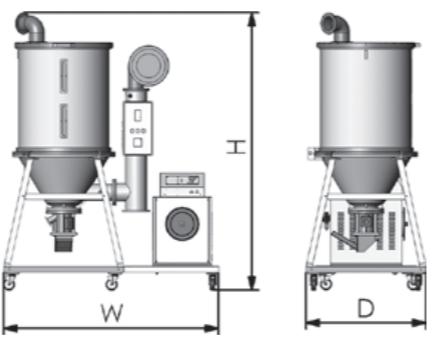

HLD-300ET-800GN - HLD-400ET-800GND

## 规格表 Specifications

机型	干燥机型号	组合上料机型号	组合料斗型号	料斗容量 L	输送能力 kg/hr	外形尺寸 HxWxD mm
HLD-25E-300GN	HHD-25E & HHD-25ET	HAL-300GN	1*MH-6L	6	350	1540x940x520
HLD-25ET-300GN		HAL-600GN				
HLD-25E-600GN		HAL-600GN-D	1*MH-6L	6+6	400	
HLD-25ET-600GN						
HLD-25E-600GND						
HLD-25ET-600GND	HHD-50E & HHD-50ET	HAL-300GN	1*MH-6L	6	350	1700x940x520
HLD-50E-300GN		HAL-600GN				
HLD-50ET-300GN		HAL-600GN-D	1*MH-6L	6+6	400	
HLD-50E-600GN						
HLD-50ET-600GN						
HLD-50E-600GND	HHD-75E & HHD-75ET	HAL-300GN	1*MH-6L	6	350	1870x940x520
HLD-50ET-600GND		HAL-600GN				
HLD-75E-300GN		HAL-600GN-D	1*MH-6L	6+6	400	
HLD-75ET-300GN						
HLD-75E-600GN						
HLD-75ET-600GN	HHD-100E & HHD-100ET	HAL-300GN	1*MH-6L	6	350	2100x980x720
HLD-75E-600GND		HAL-600GN				
HLD-75ET-600GND		HAL-600GN-D	1*MH-6L	6+6	400	
HLD-100E-300GN						
HLD-100ET-300GN						
HLD-100E-600GN	HHD-150E & HHD-150ET	HAL-300GN	1*MH-6L	6	350	2375x980x720
HLD-100ET-600GN		HAL-600GN				
HLD-100E-600GND		HAL-600GN-D	1*MH-6L	6+6	400	
HLD-100ET-600GND						
HLD-150E-300GN						
HLD-150ET-300GN	HHD-200E & HHD-200ET	HAL-300GN	1*MH-12L	12	550	2375x1380x840
HLD-150E-600GN		HAL-600GN				
HLD-150ET-600GN		HAL-600GN-D	1*MH-12L	12+12	650	
HLD-150E-600GND						
HLD-150ET-600GND						
HLD-200E-800GN	HHD-300ET	HAL-800GN	1*MH-12L	12	550	2400x1790x1000
HLD-200ET-800GN		HAL-800GN-D				
HLD-200E-800GND		HAL-800GN-D	1*MH-12L	12+12	650	
HLD-200ET-800GND						
HLD-300ET-800GN						
HLD-300ET-800GND	HHD-400ET	HAL-800GN	1*MH-12L	12	550	2460x1900x1200
HLD-400E-800GN		HAL-800GN-D				
HLD-400ET-800GN		HAL-800GN-D	1*MH-12L	12+12	650	
HLD-400ET-800GND						
HLD-400ET-800GND						

### 特点

- 干燥部分配置参考对应干燥机配置；
- 上料部分配置参考对应真空填料机配置；
- 标配含L形脚架与单管吸料盒；

### 选配项目

- 可选配排风空气滤清器、风机入口过滤器、磁力底座、磁力架、热风回收器、地上支架、移动集料箱、吸料盒等附件；
- 双层保温功能可选配；
- HLINK联网功能可选配；
- Exhaust Air Filter/Fan Inlet Filter/Magnetic Base/Magnetic Frame/Hot Air Recycling/Ground Frame/Mobile Collection Bin/Suction Box and other accessories can be optional
- Double-layer insulation cylinder function can be optional
- HLINK networking function can be optional

### 注意事项:

- 电源必须使用规定电压。
- 客户如需定制特殊规格，请与本公司联系确认。
- 产品规格若有变更，恕不另行通知

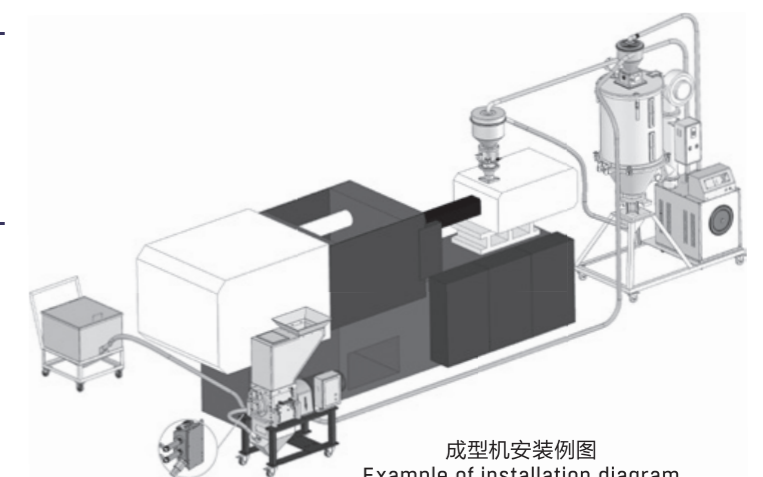

成型机安装例图  
Example of installation diagram

### Note:

- The power supply must use the specified voltage.
- Have any special needs, please contact us.
- Specifications are subject to change without prior notice.



HCD-9

# HCD

## HCD 箱式干燥机 HCD CABINET DRYER

HCD系列箱式干燥机适用于所有种类的聚合物材料烘干，能同时烘干不同的材料，非常适用于少量、多样性的原料或试模时使用，也可用于电子、电机、电镀、烤漆、印刷相关产品之预热或干燥处理。

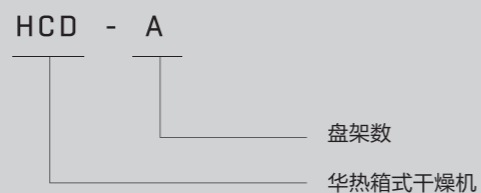

### 工作原理

箱式干燥机中，有可移动的料盘，需烘干的原料放在盘子内，运行时风车迫使空气通过电热管，再通过有很多小孔的隔墙，均匀吹进原料箱，当原料均匀烘干后，潮湿的空气由另一道墙排出。

### Working Principle

During operation, after materials being laid on removable tray, a blower forces air passing through a electro thermal tube, then through a perforated wall, and eventually goes into the material chamber. After materials being dried, the moisture will be exhausted from a outlet on the other side of the cabinet.

## 规格表 Specifications

机 型	Type		HCD-5	HCD-9	HCD-20
电热功率	Heat powe	kW	4	4.5	9
风机功率	Blower power	kW	0.37	0.37	1.5
装料量	Material loading capacity	kg	50	100	200
盘架数	Number of trays		5	9	20
重量	Weight	kg	148	178	415
内部尺寸	Internal dimension	mm	660×600×550	900×600×550	1000×900×800
外形尺寸	External dimension	mm	1200×800×620	1440×800×620	1700×1210×870

### 特 点

- 采用精密P.I.D 电子温度控制，达到均匀之烘干效果；
- 高温密封门以保持一致的温度和降低电力的损耗；
- 不锈钢材质的烤盘及内衬，可防止在烘干过程中污染原料；
- 设计利于清理保养；
- 入风口、排风口均可调式设计，可方便调节风量；
- 配置超温保护器；
- 配置马达过载保护；
- 控制面板上附电流表及主电源开关；
- 24小时定时器装置；

### Special Features

- P.I.D. accurate electronic temperature controller;
- Heat-resistant sealed door keeps constant temperature and minimize power consumption;
- Stainless steel trays and parts prevent materials from contamination;
- Designed for easy maintenance;
- Adjustable for air-in-and-air-out flow volume;
- Over temperature protector;
- Motor over load protector;
- AMP meter and main switch on control panel;
- 24 hour timer.

### 注意事项:

- 机器标准电压规格为: 3Φ 380V 50Hz。
- 客户如需定制特殊规格, 请与本公司联系确认。
- 产品规格若有变更, 恕不另行通知。

### Note:

- Standard voltage: 3 Phase 380V 50 Hz;
- Have any special needs, please contact us.
- Specifications are subject to change without prior notice.



# HED

## HED欧化料斗干燥机 EUROPEAN HOPPER DRYER

HED系列欧化料斗干燥机可以干燥因包装、运送或回收而潮湿的原料。干燥风机吹出来的风经过加热筒后变成高温干燥风，通过筒内的下吹式风管，干燥热风实现对桶内原料的均匀干燥，我们可提供装料量为25~3,000公斤的各款机型。

HED - AAA U - BBB

- 选购附件
- 装料容积 (L)
- 华热欧化料斗干燥机

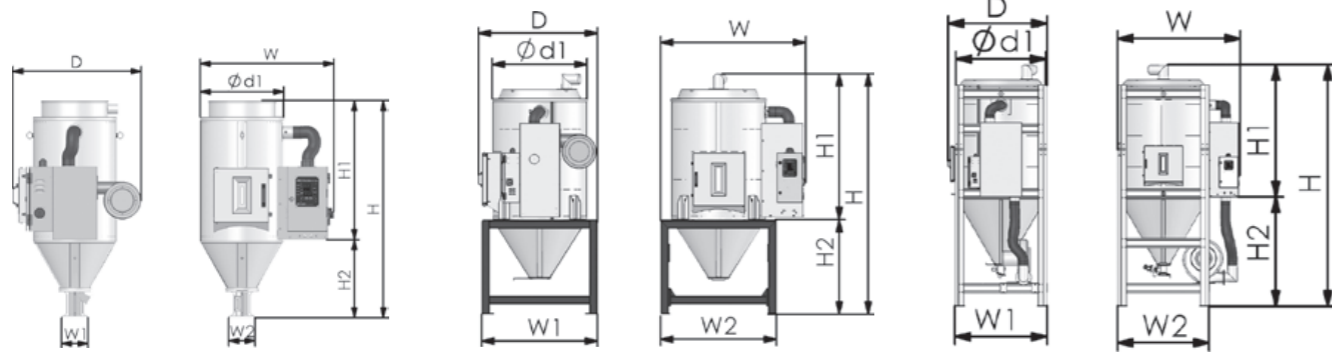

40U-120U

160U-1200U

1500U-3000U

## 规格表 Specifications

机 型		HED-40U	HED-80U	HED-120U	HED-160U	HED-230U	HED-300U	HED-450U	HED-600U
装料容积	L	40	80	120	160	230	300	450	600
装料量	kg	25	50	75	100	150	200	300	400
电热功率	kW	2	4	6	8	10	12	15	18
风机功率	kW	0.14	0.17	0.19	0.20	0.20	0.33	0.33	0.33
H	mm	1180	1315	1515	1725	1975	2085	2285	2390
H1	mm	740	840	840	1215	1215	1445	1445	1446
H2	mm	440	475	475	760	760	940	940	940
W	mm	745	810	860	880	880	1095	1095	1442
W1	mm	160	160	160	820	820	1050	1050	1150
W2	mm	160	160	160	820	820	1050	1050	1150
D	mm	735	780	860	880	880	1095	1095	1185
Ød1	mm	440	510	510	660	660	815	815	945

机 型		HED-750U	HED-900U	HED-1200U	HED-1500U	HED-2000U	HED-2500U	HED-3000U
装料容积	L	750	900	1200	1500	2000	2500	3000
装料量	kg	500	600	800	1000	1300	1600	2000
电热功率	kW	20	24	24	30	48	48	64
风机功率	kW	0.33	0.4	1.3	3.0	3.0	3.0	5.5
H	mm	2640	2865	3270	3600	4000	3835	4285
H1	mm	1446	1625	1625	2265	2265	2100	2100
H2	mm	940	1240	1240	1735	1735	1735	1735
W	mm	1442	1605	1605	1400	1400	1600	1600
W1	mm	1150	1270	1270	1250	1250	1450	1450
W2	mm	1150	1270	1270	1250	1250	1450	1450
D	mm	1185	1290	1290	1400	1400	1600	1600
Ød1	mm	945	1065	1065	1215	1215	1415	1415

### 特点

- 欧化外观，美观大气；
- 下吹式风管设计，热风分布均匀，提高干燥效率；
- 微电脑控制，控温精确，标配RS-485通讯功能；
- 料桶及内部零件一律采用不锈钢制做；
- 料桶采用双层保温隔热，热量散失少，环保节能；
- 过热保护装置，可减少人为或机械故障所产生之意外；
- 标配主电源开关&超温脱扣保护；

### 选配项目

- 可选配排风空气滤清器、风机入口过滤器、磁力底座、磁力架、热风回收器、地上支架、移动集料箱、吸料盒等附件；
- Exhaust Air Filter/Fan Inlet Filter/Magnetic Base/Magnetic Frame/Hot Air Recycling/Ground Frame /Mobile Collection Bin/Suction Box and other accessories can be optional

### 注意事项:

- 以上装料量是以颗粒直径3~5mm，堆积密度约0.65kg/L的标准塑料原料近似折算。
- 机器标准电压规格为：3Φ 380V 50Hz。
- 客户如需定制特殊规格，请与本公司联系确认。
- 产品规格若有变更，恕不另行通知。

- 一周定时自动开关机，省电便利；
- HED-900U及以上机型标配脚架；
- HED-450U及以下机型标配铝支座，HED-600U ~ 750U标配磁力底座，HED-900U及以上机型标配手动蝶阀；

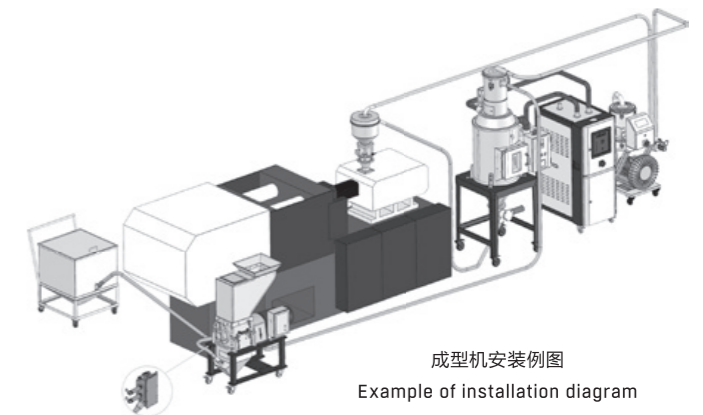

### Note:

- The above loading is based on the particle diameter of 3-5mm, the bulk density of about 0.65kg/L standard plastic raw materials approximate conversion.
- Standard voltage: 3 Phase 380V 50 Hz.
- Have any special needs, please contact us.
- Specifications are subject to change without prior notice.

# 干燥上料选购附件 OPTIONAL ACCESSORIES

## 排风空气滤清器

### Exhaust Air Filter

可有效过滤干燥机中排出的含粉尘气体，避免空气污染，保护环境，效率可达99%；

型号	适用机型
EAF-12	HHD-12E
EAF-25	HHD-25E
EAF-50	HHD-50E-75E
EAF-100	HHD-100E-150E
EAF-200	HHD-200E-1000E



EAF-50

## 风机入口过滤器

### Fan Inlet Filter

风机入口过滤，补风风量可调节，保护干燥原料洁净，提高透明料成型品质

型号	适用机型	滤桶直径 (mm)
FIF-12	HHD-12E	115
FIF-25	HHD-25E	150
FIF-50	HHD-50E-75E	150
FIF-100	HHD-100E-150E	205
FIF-200	HHD-200E-600E	205
FIF-800	HHD-800E-1000E	205



FIF-50

## 磁力底座

### Magnetic Base

螺杆下料口磁性防护，有效清理下料时原料中铁质杂物，防止铁质杂物进入料筒，保护螺杆，可与料斗磁力架组合使用；

型号	适用机型	磁力管数
MB-12	HHD-12E	3
MB-25	HHD-25E	3
MB-50	HHD-50E-75E	3
MB-100	HHD-100E-150E	5
MB-200	HHD-200E-300E	5
MB-400	HHD-400E-1000E	5



MB-50

## 磁力架

### Magnetic Frame

螺杆下料口磁性防护，有效清理料斗原料中铁质杂物，防止铁质杂物进入料筒，保护螺杆，可与磁力底座组合使用；

型号	适用机型	磁力管数
MF-5	HHD-12E	5
MF-7	HHD-25E	7
MF-9	HHD-100E-400E	9
MF-11	HHD-600E-1000E	11



MF-11

## 移动集料箱

### Mobile Collection Bins

储存原料，附有脚轮，方便移动，灵活换料；配1.5"单管吸料盒，保护原料洁净；

型号	装料量 (kg)	外形尺寸 HxWxD(mm)
MCB-50	50	770x785x560
MCB-100	100	950x880x660
MCB-150	150	1000x1020x780
MCB-200	200	1050x1050x780
MCB-400	400	1180x1315x1060
MCB-500	500	1245x1255x1060



MCB-50

## 热风回收器

### Hot Air Recycling

使干燥后热风形成半闭回路，避免厂内温度升高，保护厂内空气洁净，保证产品品质，热风回收利用，减少能耗，节约能源约40%

型号	适用机型	滤桶直径 (mm)
HAR-12	HHD-12E	115
HAR-25	HHD-25E	150
HAR-50	HHD-50E-75E	150
HAR-100	HHD-100E-150E	205
HAR-200	HHD-200E-600E	205
HAR-800	HHD-800E-1000E	205



HAR-50

## 地上支架

### Ground Frame

干燥机地面使用时，可安装于地上支架，附有脚轮，可方便移动，适合高度不足厂房，便于与机台配套。

型号	适用机型	外形尺寸 HxWxD(mm)
GF-50	HHD-12E-75E	537x850x520
GF-100	HHD-100E-150E	587x970x720
GF-200	HHD-200E	652x1240x840
GF-300	HHD-300E	775x1000x1000
GF-400	HHD-400E	1150x1200x1200
GF-600	HHD-600E-800E	1255x1300x1300
GF-1000	HHD-1000E	1635x1300x1300

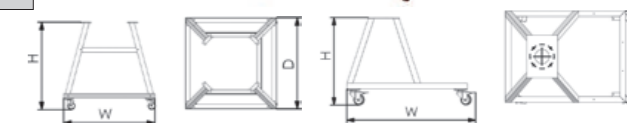

GF-50-200

GF-300-1000

## 吸料盒

### Suction Box

干燥机脚架安装时，配套吸料机使用，减轻人力，提高效率。

型号	适用机型	吸料管径
HSB-50-38S	HHD-25E-150E	1.5"
HSB-50-38D	HHD-25E-150E	1.5"x2
HSB-50-50S	HHD-25E-150E	2"
HSB-50-50D	HHD-25E-150E	2"x2
HSB-200-38S	HHD-200E-1000E	1.5"
HSB-200-38D	HHD-200E-1000E	1.5"x2
HSB-200-50S	HHD-200E-1000E	2"
HSB-200-50D	HHD-200E-1000E	2"x2



HSB-50-38S

注：带截料功能后部加"C" Note: with cut function tail mark "C"



# HCM

## HCM计量式色母混色机 METERING SCREW DOSERS



HCM系列计量式色母混色机适用于塑料成型生产中的新、次料，色母或添加剂等的物料的自动比例计量喂料。

该系列机型采用高效直流无刷马达。根据预先设定的添加比例和参数，由全数字式微电脑控制系统将设定的各项条件自动转换成转速，通过联轴器驱动SUS304不锈钢精密计量螺杆，向注塑机或挤出机熔胶筒内添加定量的物料。例如：色母料、口水料、添加剂、助剂等，其误差值不高于1%。该产品具备两种模式，分别适用于塑料的注塑成型和挤出成型。具有多款式和直径的计量螺杆可供选择，直流无刷电机搭配不同减速比的高效平行齿减速机，提供0.1-100kg/h的不同输出量供客户选择。另有双色、三色、四色色母机，根据用户需求搭配，满足不同场合、不同领域的使用。

计量混色  
Metering & Mixing

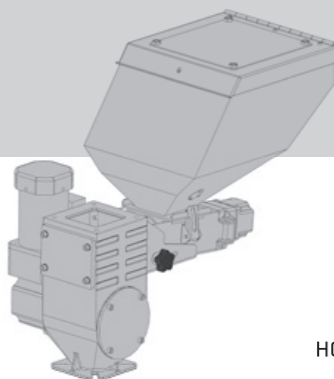

HCM-MB

HCM - A - BBB - CCC

MB= 配置搅拌底座

单色时，减速比（2位）螺杆直径（2位）  
双色时，第一组参数/第二组参数

空白 = 单色，D= 双色

华热计量式色母混色机

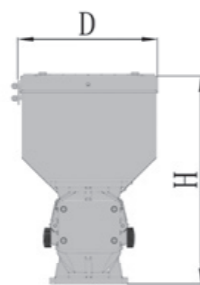
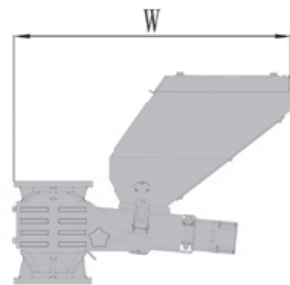

HCM

### 选配项目

- 可选配物料料位检测传感器，缺料报警提示；
- 可选配搅拌底座，确保物料混合均匀，配套100kg或以上干燥机时建议配置；
- Optional material level detection sensor, lack of material alarm prompt.
- Optional mixing base to ensure that the material mix evenly, generally supporting 100kg dryer or the above models recommended configuration.

## 规格表 Specifications

机型	Type		HCM 3012	HCM 3016	HCM 3020	HCM 3024	HCM 5020	HCM-D 30XX/30XX	HCM-D 30XX/50XX	HCM-D 50XX/50XX
组数	Group Number		1	1	1	1	1	2	2	2
减速比	Gear Ratio		30	30	30	30	50	30/30	30/50	50/50
螺杆直径	Screw Diameter	mm	12	16	20	24	20	按单组选型合并计算		
输出量	Output Capacity	kg/hr	0.1-0.38	0.3-12.3	0.9-40.3	1.4-50	0.2-24			
马达功率	Motor Power	W	30	30	30	30	30	30×2	30×2	30×2
马达转速	Motor Speed	rpm	3000	3000	3000	3000	3000	3000	3000	3000
搅拌马达功率	Mixing motor powe	W	90(选配)	90(选配)	90(选配)	90(选配)	90(选配)	90(选配)	90(选配)	90(选配)
色母料斗	Masterbatch hopper	L	12	12	12	12	12	12×2	12×2	12×2
净重	Net Weight	kg	15	15	15	15	15	28	28	28
外形尺寸										
Dimensions										
H		mm	530	530	530	530	530	615	615	615
W		mm	600	600	600	600	600	1045	1045	1045
D		mm	335	335	335	335	335	335	335	335

### 特点

- 采用直流无刷电机，无需保养，具有螺杆卡料、电压欠压、过压、过流、断线保护，保证机器连续正常运行；
- 控制器具备50组数据的永久记忆及储存功能，方便管理成型条件和配方；
- 可满足注塑机干接点和电压，挤出机0-5V、0-10V、4-20MA、2-20MA、频率、数字、等多种信号输入，几乎涵盖所有塑料成型设备的塑化信号；
- 模块式装配结构，拆装方便，可快速更换物料；
- 可用于挤出机主螺杆同步加、减速运行；
- 控制器独特的补偿优化理念，保证添加物的计量始终精准；
- 离线模拟功能，设备调试过程中，可快速调整添加物至理想分量，减少调试过程材料的损耗，大大降低换料调试时的人力以及物料消耗；
- 可配合化纤丝单丝、长丝纺丝设备使用的特殊模式，能确保纺丝设备各溶体计量泵随意调速始终保证高稳定性的助剂添加；
- 带扩展功能的特殊控制器可选配称重控制模块，实现添加料比例的数字化控制，更大程度上保证计量的准确性；
- 落料机构经过优化和改良设计的加强型安装底座，确保大色母用量也能正常使用，即使是大用量的回收料，同样可以适应·可用于挤出机主螺杆同步加、减速运行。
- 控制器独特的补偿优化理念，保证添加物的计量始终精准。
- 离线模拟功能，设备调试过程中，可快速调整添加物至理想分量，减少调试过程材料的损耗，大大降低换料调试时的人力以及物料消耗。
- 可配合化纤丝单丝、长丝纺丝设备使用的特殊模式，能确保纺丝设备各溶体计量泵随意调速始终保证高稳定性的助剂添加。
- 带扩展功能的特殊控制器可选配称重控制模块，实现添加料比例的数字化控制，更大程度上保证计量的准确性。
- 落料机构经过优化和改良设计的加强型安装底座，确保大色母用量也能正常使用，即使是大用量的回收料，同样可以适应。

### 注意事项:

- 以上输出量是比重为0.8kg/dm<sup>3</sup>直径为2-3mm的塑料粒子以连续运转的方式测得的数据，仅供参考。
- 如需要加大输出量需求或其他相关特殊要求，请与我们联系。
- 机器标准电压规格为：1Φ 220V 50Hz。
- 客户如需定制特殊规格，请与本公司联系确认。产品规格若有变更，恕不另行通知。

### Note:

- The above output is the ratio of 0.8kg / dm<sup>3</sup> diameter of 2-3mm plastic particles in continuous operation of the measured data, for reference only.
- If you need to increase the output requirements or other related special requirements, please contact us.
- Standard voltage: 1 phase, 220V, 50 Hz;
- Have any special needs, please contact us.
- Specifications are subject to change without prior notice.



# HGB

## HGB称重式拌料混色机 GRAVIMETRIC BLENDERS

HGB系列称重式拌料混色机适用于塑胶射出、压出或中空成型制程上需要多种原料按重量比例作精确混合的使用场合。

该系列产品控制器采用奥地利贝加莱控制系统，并采用自适应算法，在首次开机时能自动校准以确保精度准确，操作易学方便。

该系列产品采用高精度AD转换模块使批次的混合配比误差(视设定配比比例大小而定)能控制在±0.1%~0.5%。

可根据需要处理的物料种类多少和每小时的用量来选择适合机型，每小时处理量从40到4000多公斤。

HGB - AAA - BBB

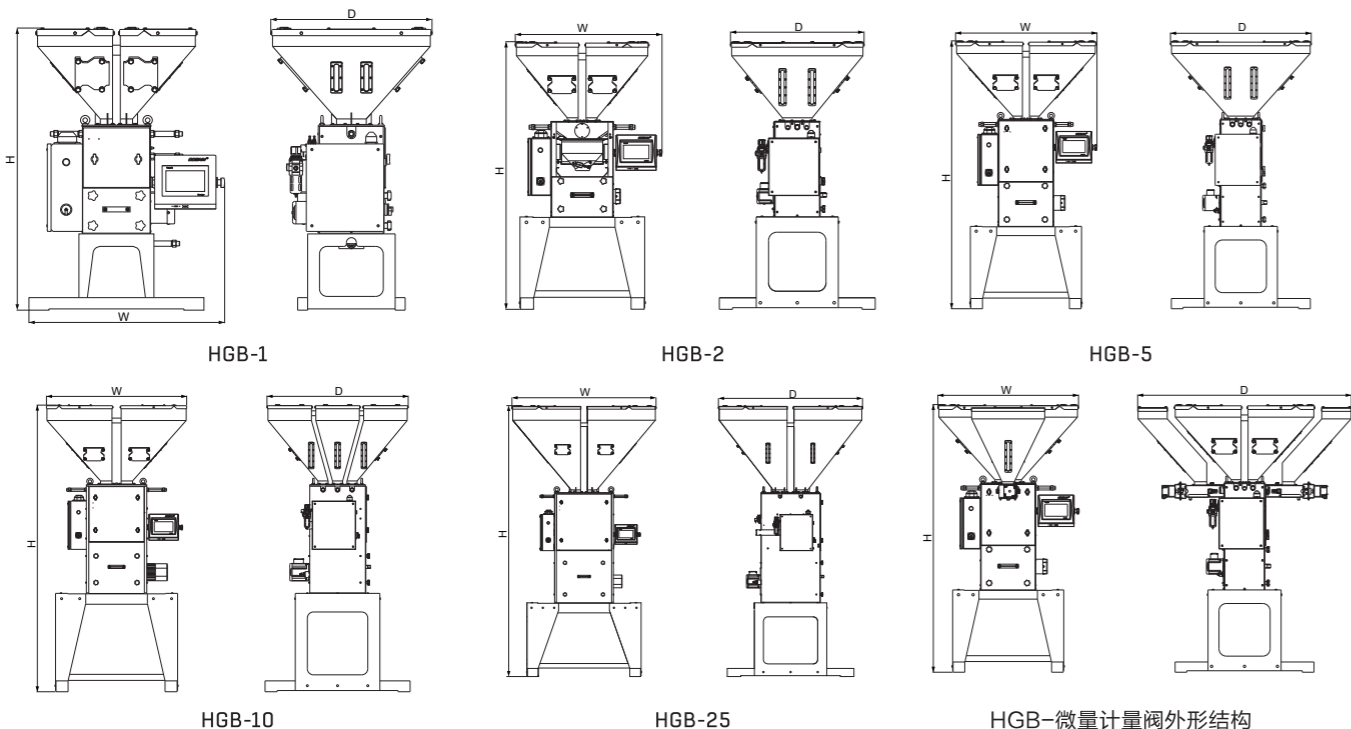
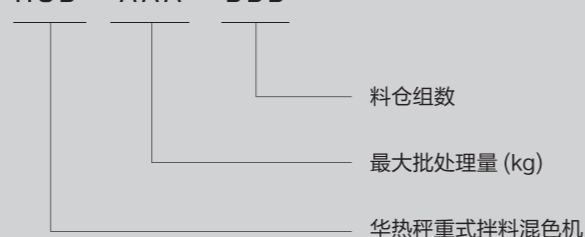

## 规格表 Specifications

机型	Type	HGB-1			HGB-2					
		-4	-3	-2	-6	-5	-4	-3	-2	
组数	Group Number	4	3	2	6	5	4	3	2	
最大产量	Max. Output	kg/hr	50	60	130	100	120	160	180	360
闸刀计量阀	Knife metering valve	Set	4	3	2	4	4	4	3	2
微量计量阀	Trace metering value	Set	-	-	-	2	1	0	0	0
最大批次处理量	Max. Throughput	Kg	1			2				
搅拌马达功率	Mixing motor power	W	90			90				
储料斗容量	Storage hopper	L	12			40				
称重斗容量	Weighing bucket capacity	L	2			8				
搅拌仓容量	Mixing warehouse capacity	L	8			18				
最大批次数	The biggest batch quantity	Hr	50	60	130	50	60	80	90	180
外型尺寸	Dimensions	mm	1150×800×650			1650×900×1300	1650×900×1050	1650×900×820		

机型	Type	HGB-5					HGB-10					HGB-25					
		-6	-5	-4	-3	-2	-6	-5	-4	-3	-2	-6	-5	-4	-3	-2	
组数	Group Number	6	5	4	3	2	6	5	4	3	2	6	5	4	3	2	
最大产量	Max. Output	kg/hr	250	300	400	450	900	670	700	900	1000	1800	1500	1750	2000	2500	4000
闸刀计量阀	Knife metering value	Set	4	4	4	3	2	6	5	4	3	2	6	5	4	3	2
微量计量阀	Trace metering value	Set	0	0	0	0	0	0	0	0	0	0	0	0	0	0	0
最大批次处理量	Max. Throughput	Kg	5					10					25				
搅拌马达功率	Mixing motor power	W	200					370					750				
储料斗容量	Storage hopper	L	48					100					150				
称重斗容量	Weighing bucket capacity	L	12					32					65				
搅拌仓容量	Mixing warehouse capacity	L	25					60					120				
最大批次数	The biggest batch quantity	Hr	50	60	80	90	180	60	70	90	100	180	60	70	80	100	160
外型尺寸	Dimensions	mm	1850×1000×1500	1850×1000×1250	1850×1000×1000	2400×1200×1200					3000×1600×1600						

### 特点

- 所有的物料通过重力计量后均匀混合，可严格控制精度；
- 先进的配料技术，可精确地控制及计量每种处理原料的配比；
- 自动重复校准功能，在每次称重后将自动修正、调整，保证最佳的配料精度；
- 最多可同时处理6种原料；
- 模块化可拆卸式设计，清洁方便；
- 具有配方储存功能，最多可存储20组配方；
- 具有报警历史记录功能；
- 标准配备为机器安装型(配备标准底座、手动关料板)；
- 可选配USB数据导出功能，将配比数据保存记录下来，便于生产质量管理；
- 改为欧规安全回路型时，机型后加注“CE”；

### 选配项目

- 该机用于地面安装时，需选配脚架、气动式排料阀、储料桶及吸料盒；

### 注意事项:

- 混合配比误差是指各组份的设定百分比与实际百分比的差值；
- 闸刀计量阀适合于5%及以上的比例，混合配比误差能控制在±0.3~0.5%；
- 螺杆或微量计量器适合于5%至0.5%的比例，混合配比误差能控制在±0.2%；
- 以上最大处理量和混合配比误差数据是以堆积密度0.8kg/L、直径为3~4mm的颗粒均匀原料以连续运转方式测量所得的数据，最大产量依计量组的多少和比例将有所不同；
- 保证气阀工作压力6kgf/cm<sup>2</sup>；
- 机器标准电压规格：HGB-5及以下机型1φ220V50Hz，HGB-10及以上机型3φ380V50Hz；
- 客户如需定制特殊规格，请与本公司联系确认。
- 产品规格若有变更，恕不另行通知。

### Note:

- You need optional mounting frame, pneumatic discharge valve, storage bin and suction box when the machine is used for ground installation,
- The mixing ratio error is the difference between the setting percentage and the actual percentage;
- The knife metering valve is suitable for the proportion of 5% and above, the mixing ratio error can be controlled in ±0.3-0.5%;
- Screw or micro-meter suitable for 5% to 0.5% ratio, mixing ratio error can be controlled in ±0.2%;
- The maximum throughput and the mixing ratio error data are based on the continuous density of 0.8 kg/L and the diameter of 3-4 mm. The maximum output will vary according to the number and proportion of the metering group.
- Please ensure the valve pressure 6kgf/cm<sup>2</sup>
- Standard voltage: HGB-5 and below models 1 Phase 220V 50 Hz, HGB-10 and above models 3 Phase 380V 50 Hz,;
- Have any special needs, please contact us.
- Specifications are subject to change without prior notice.



## 规格表 Specifications



HHS-50EA

# HHS

## HHS塑料混色机 PLASTIC COLOR MIXER

HHS系列立式混色机为颗粒状物料混色机，具有结构简单，容易操作，维护清洗方便，速度快，混合效果佳等特点。主要用于塑料胶混合拌料，也可广泛应用于：塑胶、冶金、陶瓷等行业，是一种理想的混合设备。

HHS A - BBB - CCC

- EA= 固定脚座
- EB= 脚轮架
- T= 带干燥功能 (仅 HHSL 机型)
- 混合量 (kg)
- 无 = 立式混色机
- L= 立式螺旋混色机
- 华热塑料混色机



HHS-150EB



HHSL-500

机 型	Model		HHS-50E	HHS-100E	HHS-150E	HHS-200E
			EA固定脚座Fixed feet / EB With casters	EB脚轮架 With casters		
型 式	Type		立式 Vertical type			
马达功率	Motor power	kW	1.5	3	4	5.5
混合量	Mixing capacity	kg/min	50/3	100/3	150/4	200/4
重 量	Weight	kg	150	284	305	360
外形尺寸	Dimensions	mm	790×790×1115	1035×1035×1255	1150×1150×1355	1225×1225×1480

机 型	Model		HHSL-500	HHSL-1000	HHSL-2000	HHSL-3000	HHSL-5000
型 式	Type		无干燥功能 Without drying function				
马达功率	Motor power	kW	4kW-4P	4kW-4P	5.5kW-4P	7.5kW-4P	7.5kW-6P
加热功率	Heat power	kW	无				
混合量	Mixing capacity	kg	500	1000	2000	3000	5000
外形尺寸	Dimensions	mm	Ø 1200x2650	Ø 1500x2800	Ø 1800x3250	Ø 2000x3750	Ø 2400x4200

机 型	Model		HHSL-500T	HHSL-1000T	HHSL-2000T	HHSL-3000T	HHSL-5000T
型 式	Type		带干燥功能 With drying function				
马达功率	Motor power	kW	4kW-4P	4kW-4P	5.5kW-4P	7.5kW-4P	7.5kW-6P
加热功率	Heat power	kW	12	15	20	36	40
混合量	Mixing capacity	kg	500	1000	2000	3000	5000
外形尺寸	Dimensions	mm	Ø 1200x2650	Ø 1500x2800	Ø 1800x3250	Ø 2000x3750	Ø 2400x4200

### 特 点

- 料筒和搅拌叶采用全不锈钢制造，清洗容易，绝无污染；
- 连锁安全保护装置，确保操作者及机器本身的安全；
- 用料厚，坚固耐用；
- 短时间内完成均匀混合，低能耗、高效率；
- 自动停止装置，可设定0~15分钟；

### 注意事项:

- 机器标准电压规格为: 3Φ 380V 50Hz。
- 客户如需定制特殊规格，请与本公司联系确认。
- 产品规格若有变更，恕不另行通知。

### Special Features

- Stainless steel barrel and mixing blades, easy cleaning and no contamination;
- Safety devices ensure the safety of operator and the machine itself.
- Strong and durable;
- Fast mixing, high efficiency and low power consumption;
- Timer range: 0-15 minutes.

### Note:

- Standard voltage: 3 Phase 380V 50 Hz;
- Have any special needs, please contact us.
- Specifications are subject to change without prior notice.



HAL-600GN

**HAL**

## HAL真空填料机 VACUUM AUTO-LOAD DEVIC

HAL系列自动填料机均采用不锈钢料斗，高效率真空马达，并装有马达过载保护装置及缺料自动报警器，兼具轻便耐用、吸力强、安装简便、操作容易等特性。

HAL - AAA -BBB - CCC

D= 二段  
E= 配置光电料斗  
U= 欧化配置  
  
GE= 直吸式；  
GN= 分离式；  
HP= 分离式/马达HP数

参数序号  
华热真空填料机



HAL-300GE



HAL-300GN



HAL-5HP-U

## 规格表 Specifications

机 型	Type		HAL-300GE	HAL-300GN	HAL-600GN	HAL-600GN-D	HAL-800GN	HAL-800GN-D
马达形式	Motor type		碳刷式 Carbon brush		感应式 Induction			
马达功率	Motor power	kW	1.1 (1ø)		1.5 (3ø)		2.2 (3ø)	
输送能力	conveying capacity	kg/hr	350	400	450	450	550	550
配套料斗	Matching hopper		MH-6L	MH-6L	MH-6L	MH-6L×1 PH-6L×1	MH-12L	MH-12L×1 PH-12L×1
料管/气管	Material pipe/Air pipe	Inch	1.5/1.5		1.5/1.5		1.5/1.5	
重量	Weight	kg	15	18	50	58	63	72
外形尺寸	Dimensions							
H		mm	630	490	650	770	725	845
W		mm	305	300	385	610	390	500
D		mm	515	460	515	615	575	675

机 型	Type		HAL-600GN-U	HAL-800GN-U	HAL-5HP-U	HAL-10HP-U
马达形式	Motor type		感应式 Induction			
马达功率	Motor power	kW	1.5 (3ø)	2.2 (3ø)	4.0 (3ø)	7.5 (3ø)
输送能力	conveying capacity	kg/hr	450	550	700	1400
配套料斗	Matching hopper		MH-6L	MH-12L	MH-24L	MH-36L
料管/气管	Material pipe/Air pipe	Inch	1.5/1.5	1.5/1.5	1.5/2.0	2.0/2.5
重量	Weight	kg	60	70	85	100
外形尺寸	Dimensions					
H		mm	1050	1050	1110	1430
W		mm	555	555	555	705
D		mm	630	630	630	660



HAL-300GE

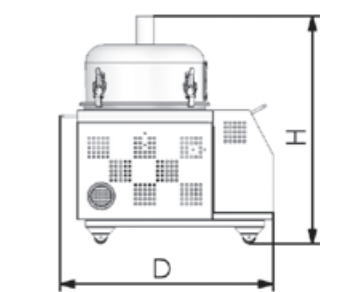
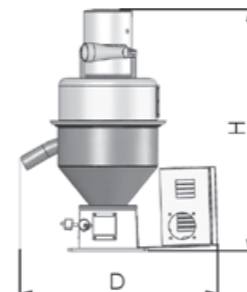

HAL-300GN

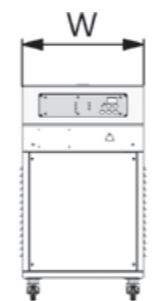

HAL-600GN ~ HAL-800GN

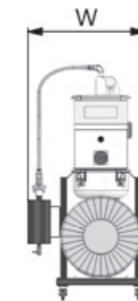
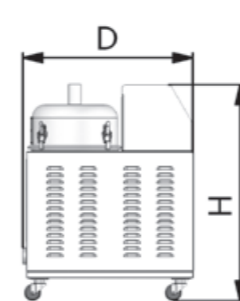

HAL-600GN-U ~ HAL-10HP-U

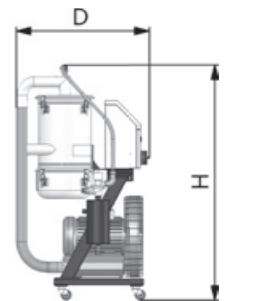





6升真空料斗 / MH-6L  
Mechanical hopper



25升真空料斗 / MH-25L  
Mechanical hopper



6升电眼料斗 / PH-6L  
Photoelectric hopper

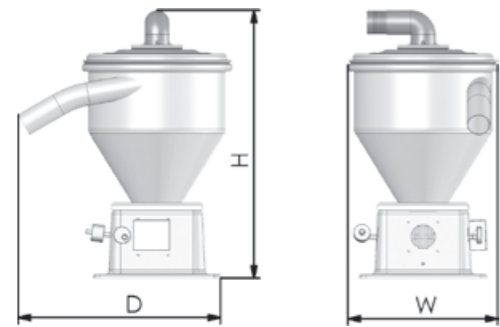

MH真空料斗  
Mechanical hopper

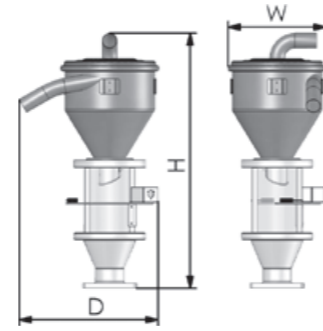

PH电眼料斗  
Photoelectric hopper

项目	Item		真空料斗 Mechanical hopper			电眼料斗 Photoelectric hopper		
			MH-6L	MH-12L	MH-25L	PH-6L	PH-12L	PH-25L
H		mm	445	545	740	645	745	940
W		mm	250	320	320	250	320	320
D		mm	335	385	385	355	385	385

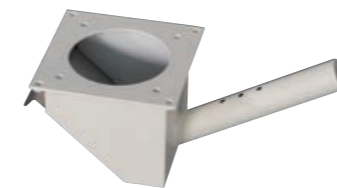

吸料盒

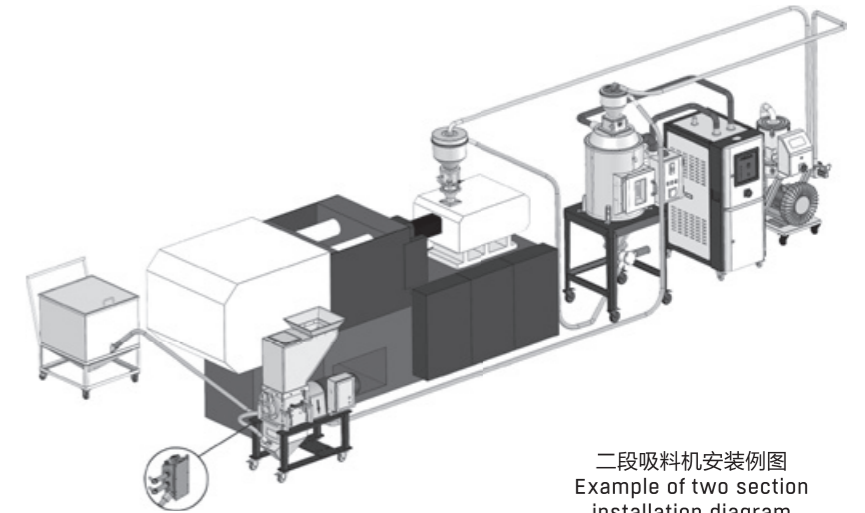

二段吸料机安装例图  
Example of two section  
installation diagram

### 特点:

- 主机与料桶采用分离式设计，安全简便；
- 微电脑控制运转；
- 控制箱独立设计，维修容易；
- 缺料自动蜂鸣警报保护装置；
- 独立滤清器装置，方便清除积尘；
- 不锈钢储料桶，轻便耐用好清料；
- 欧化配置标配 RS-485 通讯功能；
- 欧化配置标配脉冲除尘，自动清除积尘

### Special Features

- The main controller and the hopper are two separate units, safe and convenient to use.
- Equipped with micro chips.
- Independent filter and easy to clean.
- Stainless steel hopper, light, durable and easy to clean.
- Independent controller box, easy for maintenance.
- Auto alarm for idling.
- European configuration standard with RS-485 communication function.
- European configuration standard with pulse dust, automatic dust removal.

### 注意事项:

- 机器标准电压规格为：300GE 和 300GN 采用 1Φ 220V 50Hz；其余机型为 3Φ 380V 50Hz
- 客户如需定制特殊规格，请与本公司联系确认。
- 产品规格若有变更，恕不另行通知。

### Note:

- Standard voltage: 300GE AND 300GN 1 Phase 220V 50 Hz, other types 3 Phase 380V 50 Hz.
- Have any special needs, please contact us.
- Specifications are subject to change without prior notice.



**HT**

## HT皮带输送机 CONVEYOR BELT

应用于塑料制品输送或粉碎颗粒输送, 可配套应用于粉碎机  
喂料及出料输送, 或注塑制品机台至车间指定位置的传送



HT - AA - BBB - CCC

可调高度 (HTSF 机型)  
输送机长度,

皮带宽度

SF= 上行输送带平台;  
PM= 平行输送双支撑;  
PD= 平行输送单支撑

华热皮带输送机

**HTSF 450-135**

吸料输送  
Auto-Loader & Conveyor

## 规格表 Specifications

机 型	Type	HTSF 250-65	HTSF 350-65	HTSF 450-65	HTSF 250-135	HTSF 350-135	HTSF 450-135
A	mm	700	700	700	700	700	700
B	mm	1300	1300	1300	1800	1800	1800
C	mm	250	350	450	250	350	450
D	mm	368	468	568	368	468	568
E	mm	500	600	700	500	600	700
F	mm	480	580	680	480	580	680
G	mm	925+65	925+65	925+65	1130+135	1130+135	1130+135
H	mm	330+65	330+65	330+65	192+135	192+135	192+135
L	mm	1825	1825	1825	2230	2230	2230
M	mm	495	495	495	650	650	650
N	mm	750	750	750	910	910	910

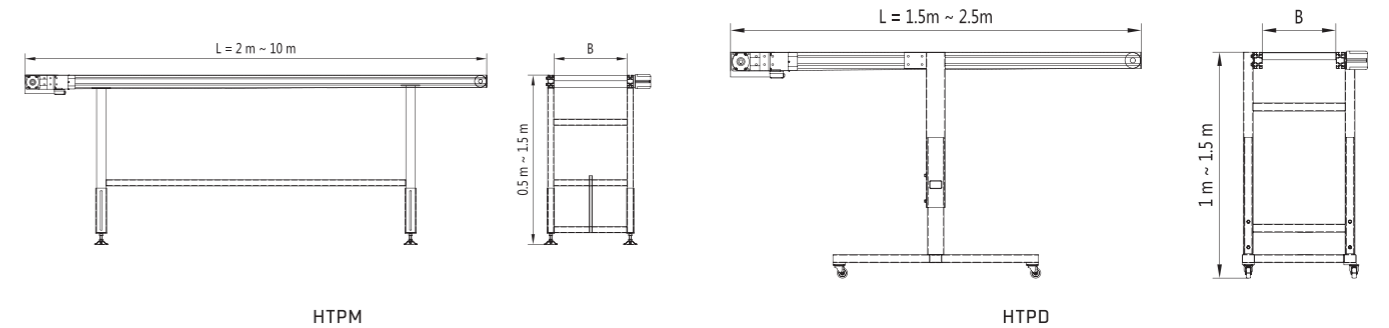

机 型	Type	HTPM 250L	HTPM 350L	HTPM 450L	HTPM 600L	HTPM 800L	HTPM 1000L	HTPD 250L	HTPD350L	HTPD450L
B	mm	250	350	450	600	800	1000	250	350	450

### 特 点:

- 整体式钣金成型, 刚性强, 不易变形;
- 欧式设计, 可靠耐用, 使用寿命长;
- 移动灵活, 高度可调节;
- 可实现与其他平面输送机接驳使用;
- 免于安装, 调整操作简单;

### Special Features:

- Integral sheet metal forming, steel is strong and difficult to deformed.
- European-style design, reliable, durable and long life.
- Moving flexible, height can be adjusted.
- Achieved with another planar conveyor belts connected to use.
- Easy install, adjust and operate.

### 注意事项:

- 电源必须使用规定电压。
- 客户如需定制特殊规格, 请与本公司联系确认。
- 产品规格若有变更, 恕不另行通知。

### Note:

- The power supply must use the specified voltage.
- Have any special needs, please contact us.
- Specifications are subject to change without prior notice.

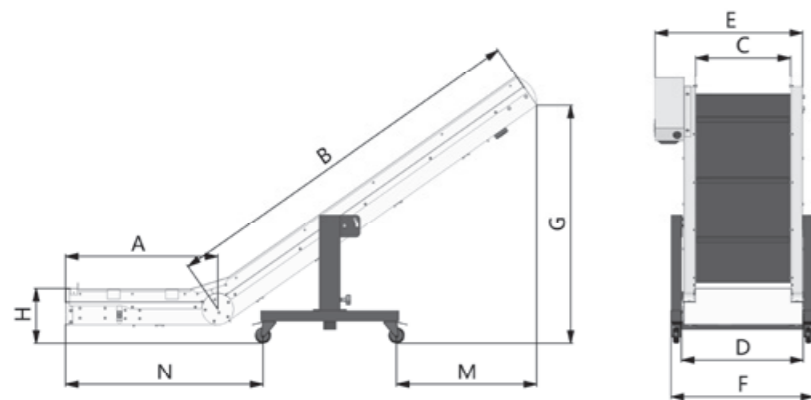



HC-05ACI



## HC工业冷水机 INDUSTRIAL CHILLER

HC系列工业冷水机主要适用于塑胶工业,它可以精确的控制塑胶成型模具温度以缩短成型周期,加速产品定型;也适用于冷却各种液压机以稳定的保持其工作油温;另外也适用于电镀业/食品业/电子业及漂染业等其他行业。该系列冷水机在结构上它区分风冷式及水冷式两种,能精确又稳定的提供温度在5~30℃冰水(温差不超过±1℃),冷却能力6,800至120,000kcal/hr。

HC - AAA - BBB - CCC

D= 双机头  
T= 三机头  
L= 双层式水冷机型

ACI= 风冷盘管  
SACI= 风冷壳管  
PACI= 风冷板换  
WCI= 水冷盘管  
SWCI= 水冷壳管  
PWCI= 水冷板换

压缩机 HP 数

华热工业冷水机



HC-03WCI



HC-05WCI-L (双层式 two layer type)



### 特点:

- 采用欧美进口高质全新设计压缩机及名牌水泵、风机,省电耐用;
- 独有全新设计之散热器,换热效能佳;
- 备有不锈钢开放式水箱,清洗维护方便快捷;
- 配备微电脑温度控制器,精确控温±1℃;
- 本机标准配置自动补水功能,逆缺相保护,电流过载保护,高低压保护及多项电子时间延迟等安全保护与功能,当发生故障时,随即发出警报。
- 双机头机型压缩机累计时间轮值开机,有效均衡运行时间,提升机器寿命。

### Special Features:

- Using European and the United States imports of high-quality design compressor and brand-name pumps, fans, Power saving and durable.
- Unique new design of the heat exchanger, heat transfer efficiency.
- Equipped with stainless steel open tank, cleaning repair convenient and quick.
- Equipped with microcomputer temperature controller, precise temperature control ±1℃.
- Standard with automatically water function, reverse phase protection, current overload protection, high and low pressure protection and a number of electronic time delay and other security protection and function, when a failure occurs immediately issued an alarm.
- In double head models machine the compressor according to the cumulative time to run as a host rotation, effective balance the two compressors running time, improve machine life

### 选配项目:

- 可选配: R407C环保冷媒机型、多口分流管、高扬程泵浦、外部水箱等要求;
- HLINK联网功能可选配;
- R407C environmentally friendly refrigerant, multi-tube water row, high-lift pump, external water tanks and other requirements can be optional
- HLINK networking function can be optional.

### 注意事项:

- 机器标准电压规格为: 3Φ 380V 50Hz。
- 机型的选择取决于注塑重量和所需制冷量。
- 客户如需定制特殊规格, 请与本公司联系确认。
- 产品规格若有变更, 恕不另行通知。

### Note:

- The standard voltage is 3 Phase 380V 50Hz.
- Refer to the shot weight and cooling capacity to select the machine.
- Have any special needs, please contact us.
- We reserve right to change specifications without prior notice.

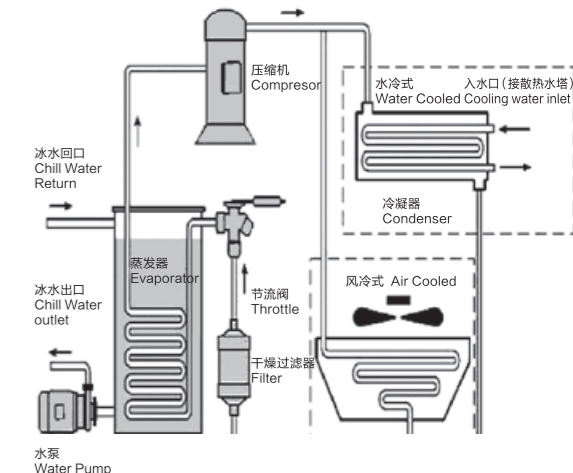

盘管蒸发器  
coil evaporator  
HC-xxACI  
HC-xxWCI



板换蒸发器  
Board evaporator  
HC-xxPACI  
HC-xxPWCI



壳管蒸发器  
Shell evaporator  
HC-xxSACI  
HC-xxSWCI

## 规格表 Specifications

### Air

#### Cooled Cased Industrial Chiller

#### 风冷箱式工业冷水机

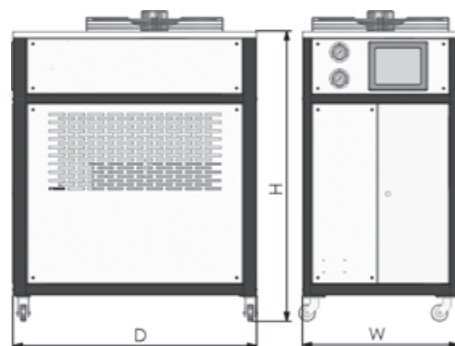

机 型	Type		Unit	HC-03ACI	HC-05ACI	HC-08ACI	HC-10ACI	HC-12SACI	HC-15SACI	HC-20SACI-D	HC-25SACI-D	HC-30SACI-D	HC-40SACI-D	HC-50SACI-D	
制冷量	Cooling capacity		kW	8	14	22	30	37	42	52	62	86	104	125	
			Kcal/h	6800	12040	19000	25200	32000	37000	45000	54000	74000	90000	108000	
压缩机	Compressor	类型	type	全封闭涡旋式 All-close scroll											
		功率	power	kW	2.5	4.4	7	9	10.5	13.4	9×2	10.5×2	13.4×2	17.8×2	20×2
冷冻媒体	Refrigerant	类型	type	R22(R407C)											
蒸发器	Evaporator	类型	type	水箱沉浸式 Water tank immersion					壳管式蒸发器 Shell evaporator						
		类型	type	翅片式冷凝器 Finned condenser											
风冷冷凝器	Air cooled condenser	类型	type												
		风机功率	fan power	kW	0.25	0.6	0.25×2	0.45×2	0.45×2	0.6×2	0.45×4	0.6×4	0.6×4	0.6×6	0.7×6
水泵	Pump	功率	power	kW	0.75	0.75	1.5	1.5	1.5	3	3	3	4	5.5	5.5
		流量	flow	L/min	83	83	208	208	208	330	330	330	500	660	660
水箱容量	Water tank capacity		L	100	100	160	200	160	160	250	250	320	450	450	
冷冻水接管口径	Frozen water inlet and outlet pipe		Inch	1	1	1.5	1.5	1.5	2	2	2	2.5	2.5	3	
重量	Weight		kg	190	220	310	390	420	520	800	810	860	1000	1120	
外形尺寸	Dimensions														
H			mm	1250	1250	1450	1500	1500	1700	1800	1800	1900	1940	1940	
W			mm	680	680	700	800	900	960	1600	1600	1900	1950	1950	
D			mm	1060	1060	1360	1470	1470	1580	1480	1480	2400	2540	2840	

### Water

#### Cooled Cased Industrial Chiller

#### 水冷箱式工业冷水机

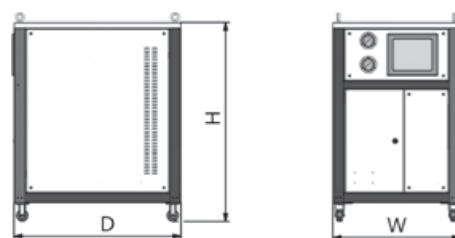

机 型	Type		Unit	HC-03WCI	HC-05WCI	HC-08WCI	HC-10WCI	HC-12SWCI	HC-15SWCI	HC-20SWCI-D	HC-25SWCI-D	HC-30SWCI-D	HC-40SWCI-D	HC-50SWCI-D	
制冷量	Cooling capacity		kW	9	15	25	32	40	48	58	70	95	115	140	
			Kcal/h	7580	13500	21150	28000	34000	41000	50000	60000	82000	100000	120000	
压缩机	Compressor	类型	type	全封闭涡旋式 All-close scroll											
		功率	power	kW	2.5	4.4	7	9	10.5	13.4	9×2	10.5×2	13.4×2	17.8×2	20×2
冷冻媒体	Refrigerant	类型	type	R22(R407C)											
蒸发器	Evaporator	类型	type	水箱沉浸式 Water tank immersion					壳管式蒸发器 Shell evaporator						
		类型	type	壳管式冷凝器 Shell condenser											
水冷冷凝器	Water cooled condenser	类型	type												
		冷却水量	water flow	L/min	≥36	≥60	≥100	≥135	≥160	≥200	≥135×2	≥160×2	≥200×2	≥240×2	≥300×2
水泵	Pump	功率	power	kW	0.75	0.75	1.5	1.5	1.5	3	3	3	4	5.5	5.5
		流量	flow	L/min	83	83	208	208	208	330	330	330	500	660	660
水箱容量	Water tank capacity		L	60	60	120	130	150	180	250	250	310	380	470	
冷却水接管口径	Chilled water inlet and outlet pipe		Inch	1	1	1.5	1.5	1.5	2	1.5×2	1.5×2	2×2	2.5×2	2.5×2	
冷冻水接管口径	Frozen water inlet and outlet pipe		Inch	1	1	1.5	1.5	1.5	2	2	2	2.5	2.5	3	
重量	Weight		kg	165	180	260	340	380	450	740	750	800	920	1000	
外形尺寸	Dimensions														
H			mm	1000	1000	1200	1200	1200	1360	1360	1360	1380	1470	1470	
W			mm	650	650	800	800	800	1000	1200	1200	1250	1400	1400	
D			mm	850	850	1050	1200	1300	1550	1800	1800	1900	2050	2050	

制冷量基于以下工况测得:

- 冷冻水出水温度15℃
- 冷却水进水温度30℃
- 空气温度35℃
- Chilled water outlet temperature is 15 degrees
- Cooling water inlet temperature is 30 degrees
- Air temperature is 35 degrees



## HC螺杆式工业冷水机 SCREW TYPE INDUSTRIAL CHILLER



HC-50WSCS

HC螺杆式冷水机组系列可提供5~30℃，冰水（温差不超过±1℃），在结构上它区分风冷式和水冷式两种，制冷量从82,300~365,840kcal/hr，可广泛应用于制冷量特别大的行业，该机采用国际先进半封闭螺杆压缩机，电机压缩机一体化，无轴封渗漏之虑，具有安全可靠经济的特点。

HC - AAA - BBB

ASCS= 风冷壳管螺杆单机  
ASCD= 风冷壳管螺杆双机  
WSCS= 水冷壳管螺杆单机  
WSCD= 水冷壳管螺杆双机

压缩机 HP 数

华热螺杆式工业冷水机组

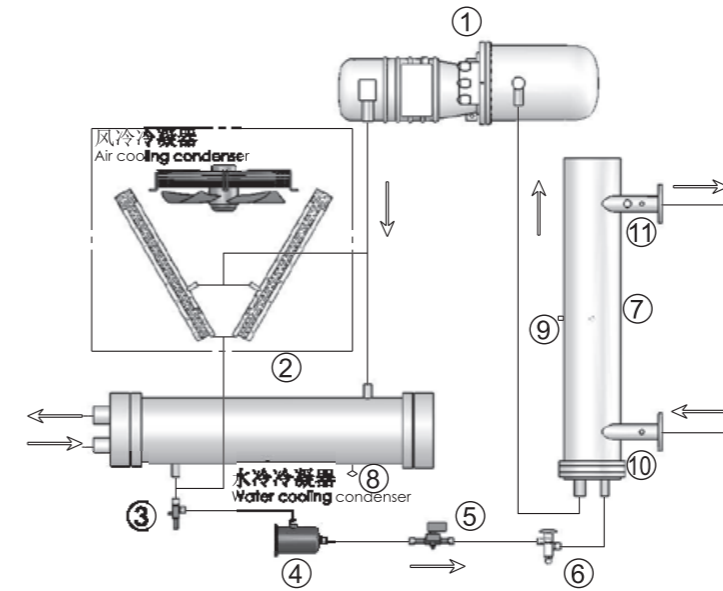

- |          |                          |
|----------|--------------------------|
| 1 压缩机    | Compressor               |
| 2 冷凝器    | Condenser                |
| 3 出液角阀   | Angle valve              |
| 4 干燥过滤器  | Drying filter            |
| 5 电磁阀    | Solenoid valve           |
| 6 膨胀阀    | Expansion valve          |
| 7 蒸发器    | Evaporator               |
| 8 可溶栓    | Fusible plug             |
| 9 防冻保护   | Anti-freezing protection |
| 10 感温探头  | Temperature sensor       |
| 11 水流量开关 | Water flow switch        |

### 特点：

- 本机组采用进口优质品牌半封闭式螺杆压缩机高效、稳定、节能、低噪；  
100%-75%-50%-25%四段分级冷量调节，平稳运行，电流冲击小，节约能源；
- 本机采用制冷专用微电脑控制器配套大屏液晶触摸屏，实现全功能自动化控制。人机界面友好，即时显示机器工作状态，操作简便；
- 本机组采用高效壳管蒸发器配套水冷壳管冷凝器或风冷翅片冷凝器，保证机组高效运行；
- 本机组标配逆缺相保护、过电流保护、短路保护、压缩机过热保护、高低压保护、水流检测防冻保护、四段分级冷量运行、压力安全阀等多项安全保护功能。
- 螺杆冷水机组均按客户实际工程情况配套应用，因此机组所需之保温水箱、水泵及外部管路选均需按实际应用情况选配，机组标准配置未包含上述部件；

### 注意事项 Note:

- 机器标准电压规格为：3Φ 380V 50Hz。
- 机型的选择取决于注塑重量和所需制冷量。
- 客户如需定制特殊规格，请与本公司联系确认。
- 产品规格若有变更，恕不另行通知。

### Note:

- The standard voltage is 3 Phase 380V 50Hz.
- Refer to the shot weight and cooling capacity to select the machine.
- Have any special needs, please contact us.
- We reserve right to change specifications without prior notice.

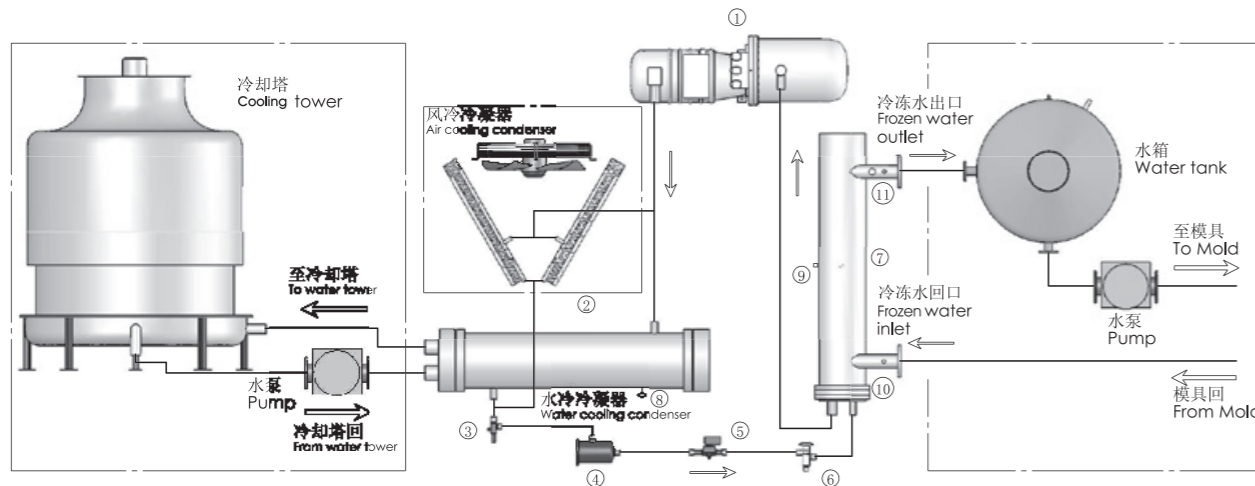

螺杆式工业冷水机组原理图  
Schematic diagram of industrial screw chillers

# 规格表 Specifications

## Air Cooled screw chillers 风冷螺杆冷水机组

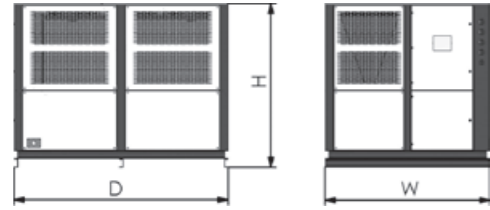

## Water Cooled screw chillers 水冷螺杆冷水机组

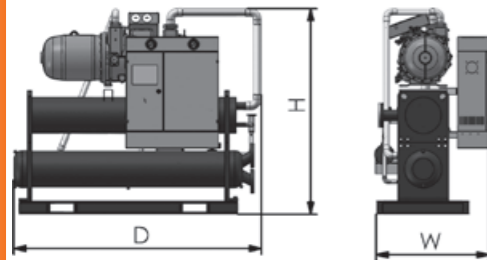

制冷量基于以下工况测得:

- 冷冻水出水温度15℃
- 冷却水进水温度30℃
- 空气温度35℃
- Chilled water outlet temperature is 15 degrees
- Cooling water inlet temperature is 30 degrees
- Air temperature is 35 degrees

类别	Sort	单压缩机系列 Single compressor series					双压缩机系列 Double compressor series					
机型	Type	Unit	HC-50ASCS	HC-60ASCS	HC-70ASCS	HC-80ASCS	HC-100ASCS	HC-120ASCD	HC-140ASCD	HC-160ASCD		
额定制冷量	Rating cooling capacity	Kcal/h	104570 (125484)	118500 (142200)	137420 (164904)	158840 (190608)	209000 (250800)	237000 (284400)	274800 (329760)	317600 (381120)		
		kW	121.6 (145.92)	137.8 (165.36)	159.8 (191.76)	184.7 (221.64)	243 (291.6)	275 (330)	320 (384)	370 (444)		
		Btu/h	414960 (497952)	470240 (564288)	545320 (654384)	630320 (756384)	829920 (995904)	940480 (1128576)	1090640 (1308768)	1659840 (1991808)		
		Ton	34.6 (41.5)	39.2 (47.0)	45.4 (54.5)	52.5 (63.0)	69.1 (83.0)	78.4 (94.0)	90.9 (109.0)	105.0 (126.0)		
输入电源	Electrical source	3Φ 380V 50Hz(3Φ 380V 60Hz)										
输入功率	Power	kW	41.2	49.2	57.6	66.4	82	99.6	115.2	136.8		
制冷剂流量控制	Flowrate refrigerant control	热力膨胀阀 Heating power expanding valve										
制冷回路	Cooling loop		1	1	1	1	1	2	2	2		
压缩机	Compressor	类别	半封闭螺杆压缩机 Semi isolated screw compressor									
		数量	1	1	1	1	1	2	2	2		
		启动方式	Y-Δ启动/Y-Δ start up									
		容量控制	100%-75%-50%-25%									
冷凝器	Condenser	类别	高效翅片式High performance finned condenser									
		冷却风量	Cooling air flow	m <sup>3</sup> /h	63000	76000	90000	105000	132000	157000	183000	209000
		冷却风机功率	Fan power	kW	0.7x6	0.7x6	0.7x8	0.8x8	0.8x10	0.8x12	0.8x14	1.2x14
蒸发器	Evaporator	类别	高效内螺纹壳管式High performance female screw shell									
		冷冻水流量	Frozen water flow	L/min	440	500	570	660	880	1000	1140	1320
		接管口径	Take-over diameter	Inch	2.5	3	3	3	3	4	4	4
安全保护装置	Safeguard protection	电源熔断器、压缩机过热保护、过流保护、高低压保护、防冻保护、流量开关、相序/缺相保护、排气过热保护 Power fuse, compressor overheat protection, overflow protection, high/low pressure protection, Frost protection, rate switch, converse protection, exhaust overheat protection										
重量	Weight	kg	1700	1800	2100	2300	2700	3500	3800	4200		
外形尺寸	Dimensions											
H		mm	1940	1940	1940	1940	1940	1940	1940	1940		
W		mm	1950	1950	1950	1950	1950	1950	1950	1950		
D		mm	2840	3240	3550	4250	4650	5050	5450	6500		

类别	Sort	单压缩机系列 Single compressor series					双压缩机系列 Double compressor series					
机型	Type	Unit	HC-50WSCS	HC-60WSCS	HC-70WSCS	HC-80WSCS	HC-100WSCS	HC-120WSCD	HC-140WSCD	HC-160WSCD		
额定制冷量	Rating cooling capacity	Kcal/h	124870 (149844)	136480 (163776)	158240 (189888)	182920 (219504)	249740 (299688)	272960 (327552)	316480 (379776)	365840 (439008)		
		kW	161.6 (193.92)	176 (211.2)	204 (244.8)	236 (283.2)	323 (387.6)	352 (422.4)	408 (489.6)	472 (566.4)		
		Btu/h	500000 (600000)	542000 (650400)	628000 (753600)	726000 (871200)	1000000 (1200000)	1084000 (1300800)	1256000 (1507200)	1452000 (1742400)		
		Ton	41.3 (49.6)	45.1 (54.2)	52.3 (62.8)	60.5 (72.6)	82.6 (99.1)	90.3 (108.3)	104.7 (125.6)	121.0 (145.2)		
输入电源	Electrical source	3Φ 380V 50Hz(3Φ 380V 60Hz)										
输入功率	Power	kW	37	45	52	60	74	90	104	120		
制冷剂流量控制	Flowrate refrigerant control	热力膨胀阀 Heating power expanding valve										
制冷回路	Cooling loop		1	1	1	1	1	2	2	2		
压缩机	Compressor	类别	半封闭螺杆压缩机 Semi isolated screw compressor									
		数量	1	1	1	1	1	2	2	2		
		启动方式	Y-Δ启动/Y-Δ start up									
		容量控制	100%-75%-50%-25%									
冷凝器	Condenser	类别	高效外螺纹壳管式High performance male screw shell									
		冷却水量	Cooling water flow	L/min	650	710	825	950	1300	1420	1650	1900
		接管口径	Inch	2.5	3	3	3	3	4	4	4	
蒸发器	Evaporator	类别	高效内螺纹壳管式High performance female screw shell									
		冷冻水流量	Frozen water flow	L/min	520	570	660	760	1040	1140	1320	1520
		接管口径	Take-over diameter	Inch	2.5	3	3	3	3	4	4	4
安全保护装置	Safeguard protection	电源熔断器、压缩机过热保护、过流保护、高低压保护、防冻保护、流量开关、相序/缺相保护、排气过热保护 Power fuse, compressor overheat protection, overflow protection, high/low pressure protection, Frost protection, rate switch, converse protection, exhaust overheat protection										
重量	Weight	kg	900	1100	1350	1500	1800	2300	2600	2800		
外形尺寸	Dimensions											
H		mm	1550	1800	1800	1830	1880	2150	2250	2350		
W		mm	860	990	990	990	990	990	990	990		
D		mm	1850	2180	2250	2450	2700	3500	3650	3850		



HMC-6W



HMC-9WP

# HMC-W

## HMC-W 水式模具温度控制机 WATER MOLD TEMPERATURE CONTEOLLER

HMC-W水式模温机主要用于模具的恒温与加热，也适用于有同样工况需求的其他领域，使用普通水为传热媒介，通过高压环境下水的沸点升高这一特性，并利用水的低粘滞性，达到快速升温、恒温的热交换效果。

HMC - AAA - BBB - CCC

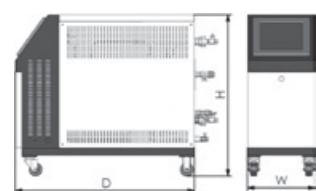

HMC-6W-9W

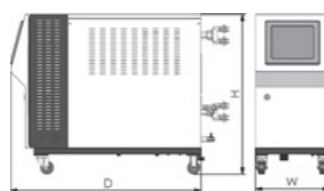

HMC-12W-24W



HMC-WP

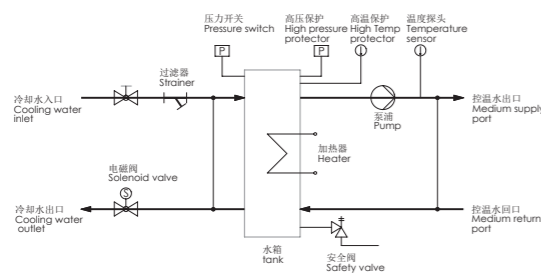

HMC-WG

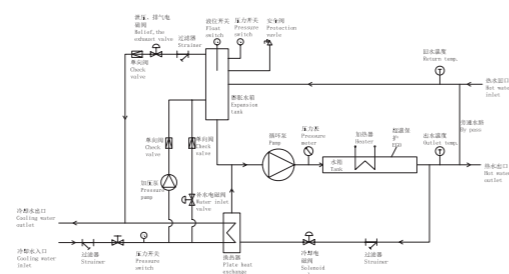

HMC-WP

## 规格表 Specifications

机 型	Type	Unit	HMC-6W HMC-6WG	HMC-9W HMC-9WG	HMC-12W HMC-12WG	HMC-18W HMC-18WG	HMC-24W HMC-24WG	HMC-6W-D HMC-6WG-D	HMC-9W-D HMC-9WG-D	HMC-12W-D HMC-12WG-D
使用媒介	Medium		清水Water							
最高温度	Max temp	℃	W=90℃ WG=120℃							
电热功率	Heat power	kW	6	9	12	18	24	6x2	9x2	12x2
泵浦功率	Pump power	kW	0.37	0.75	0.75	1.5	2.2	0.37x2	0.75x2	0.75x2
最大流量	Max pump flow	L/min	42	56	135	160	315	42x2	56x2	135x2
最高压力	Max pump pressure	Bar	2.8	3.8	2.5	2.7	3.0	2.8	3.8	2.5
冷却方式	Cooling method		直接式 Direct							
接口管径	Mould coupling	W	Φ10(2x2)	Φ10(2x2)	Φ10(4x2)	Φ10(6x2)	Φ10(6x2)	Φ10(2-2x2)	Φ10(2-2x2)	Φ10(2-4x2)
		WG	3/8"(2x2)	3/8"(2x2)	3/8"(4x2)	3/8"(6x2)	3/8"(6x2)	3/8"(2-2x2)	3/8"(2-2x2)	3/8"(2-4x2)
外形尺寸	Dimensions									
H		mm	770	770	905	1025	1025	770	770	920
W		mm	310	310	350	350	410	660	660	660
D		mm	790	840	755	755	885	790	840	840

机 型	Type	Unit	HMC-9WP	HMC-9WP3	HMC-9WP-D	HMC-9WP3-D
使用媒介	Medium		清水Water			
最高温度	Max temp	℃	160℃			
电热功率	Heat power	kW	9	9	9x2	9x2
泵浦功率	Pump power	kW	0.75	2.2	0.75 x 2	2.2 x 2
最大流量	Max pump flow	L/min	135	240	135 x 2	240 x 2
最高压力	Max pump pressure	Bar	2.5	3.6	2.5 x 2	3.6 x 2
冷却方式	Cooling method		间接式 Indirect			
接口管径	Mould coupling	inch	3/8"(4x2)	3/8"(4x2)	3/8"(2-4x2)	3/8"(2-4x2)
外形尺寸	Dimensions					
H		mm	775	825	775	825
W		mm	350	380	700	760
D		mm	915	965	915	965

### 特点:

- HMC-W水式模温机最高控温: 90度;
- HMC-WG水式模温机最高控温: 120度;
- HMC-WP水式模温机最高控温: 160度;
- 采用模温专用液晶显示微电脑控制器, 显示直观, 操作简单, 性能稳定, 功能完善;
- 双路PID模糊控制算法, 高精度调节媒介温度, 控温精度: ±1度;
- 配备优质高温介质移送循环泵浦, 采用耐高温密封, 运行性能稳定;
- 异常故障警示准确直接, LCD面板输出警报文本并通过指示灯, 蜂鸣器提醒用户;
- 电气配电箱采用隔离设计, 散热好;
- 结构合理, 维修方便, 内部构件采用不锈钢材料, 耐高压, 不生锈钢。
- W系列标准配置泵浦过载, 逆缺相保护和进水低压检测、自动排气补水等多项安全保护功能, 确保使用安全可靠;
- WG系列标准配置泵浦过载保护, 逆缺相保护, 超温保护, 超压保护和进水低压检测、自动排气补水、自动安全泄压等多项安全保护功能, 确保使用安全可靠;
- WP系列标准配置泵浦过载保护, 逆缺相保护, 超温保护, 超压保护、低液位保护和进水低压检测、自动排气补水、自动安全泄压、间接冷却等多项安全保护功能, 确保使用安全可靠;

### 选配项目:

- 可选配: 多口分流管、压力显示、回媒温度显示等要求;
- HLINK联网功能可选配;
- Multi-tube water row, pressure display, return media temperature display and other requirements can be optional
- HLINK networking function can be optional

### 注意事项 Note:

- 机器标准电压规格为: 3Φ 380V 50Hz。
- 机型的选择取决于所需的制热量。
- 客户如需定制特殊规格, 请与本公司联系确认。
- 产品规格若有变更, 恕不另行通知。
- The standard voltage is 3 Phase 380V 50Hz.
- Refer to the heating capacity to select the machine.
- Have any special needs, please contact us.
- We reserve right to change specifications without prior notice.



HMC-6H

# HMC-H

## HMC-H油式模具温度控制机 OIL MOLD TEMPERATURE CONTROLLER

HMC系列模温机用于塑料成型模具以及挤出成型滚筒的温度调节。通过加热装置和冷却装置来高精度地控制模具及滚筒的温度。



HMC-9HT

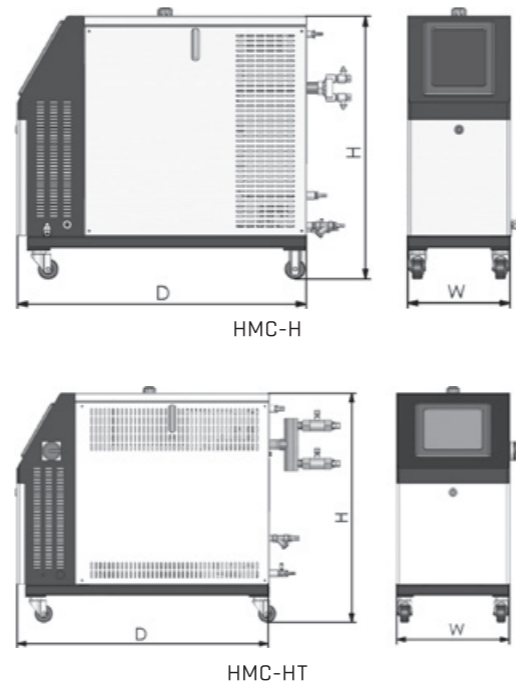
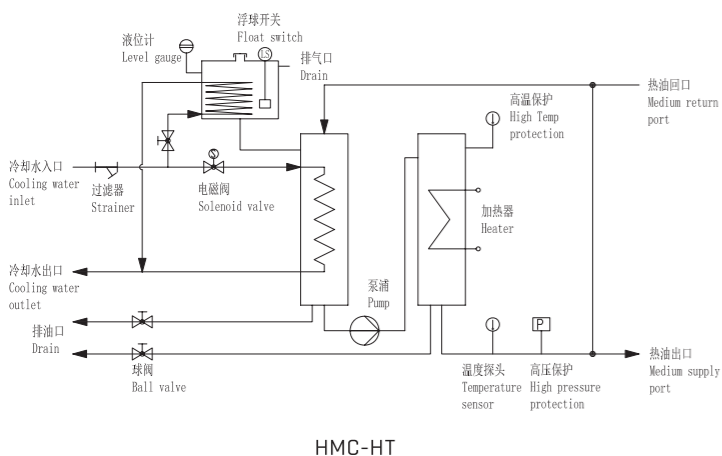
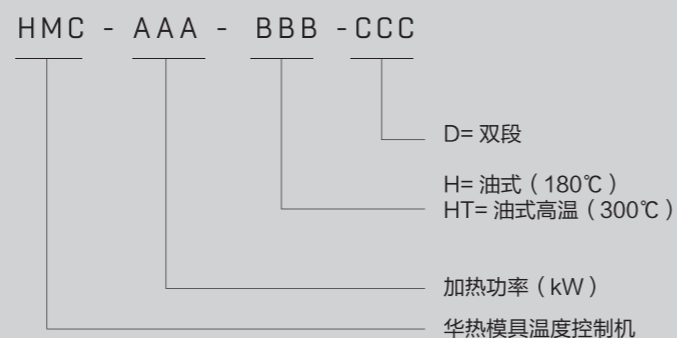

## 规格表 Specifications

机型	Type	Unit	HMC-6H	HMC-9H	HMC-12H	HMC-18H	HMC-24H	HMC-6H-D	HMC-9H-D	HMC-12H-D
使用媒介	Medium		高温导热油 High temperature conducting oil							
最高温度	Max temp	℃	180℃							
电热功率	Heat power	kW	6	9	12	18	24	6x2	9x2	12x2
泵浦功率	Pump power	kW	0.37	0.75	0.75	1.5	2.2	0.37x2	0.75x2	0.75x2
最大流量	Max pump flow	L/min	42	56	135	160	315	42x2	56x2	135x2
最高压力	Max pump pressure	Bar	2.8	3.8	2.5	2.7	3.0	2.8	3.8	2.5
冷却方式	Cooling method		间接式 Indirect							
接口管径	Mould coupling		3/8"(2x2)	3/8"(2x2)	3/8"(4x2)	3/8"(6x2)	3/8"(6x2)	3/8"(2-2x2)	3/8"(2-2x2)	3/8"(2-4x2)
外形尺寸	Dimensions									
H		mm	740	790	790	890	890	740	790	790
W		mm	310	310	310	390	390	660	660	660
D		mm	720	770	870	980	980	720	770	870

机型	Type	Unit	HMC-9HT	HMC-12HT	HMC-18HT	HMC-24HT
使用媒介	Medium		高温导热油 High temperature conducting oil			
最高温度	Max temp	℃	300℃			
电热功率	Heat power	kW	9	12	18	24
泵浦功率	Pump power	kW	0.5	1	2.8	2.8
最大流量	Max pump flow	L/min	30	58	80	80
最大压力	Max pump pressure	Bar	5	5.5	10	10
冷却方式	Cooling method		间接冷却 Indirect cooling			
冷却水配管	Cooling water pipe	inch	1/2"	1/2"	1/2"	1/2"
循环油配管	Circulation oil pipe	inch	1/2"(2x2)	1/2"(2x2)	3/4"(2x2)	3/4"(2x2)
外形尺寸	Dimensions					
H		mm	790	790	975	975
W		mm	390	390	390	390
D		mm	870	870	950	950

### 特点:

- HMC-H油式模温机最高控温: 180度;
- HMC-HT油式高温模温机最高控温: 300度;
- 采用模温专用液晶显示微电脑控制器, 显示直观, 操作简单, 性能稳定, 功能完善;
- 双路PID模糊控制算法, 高精度调节媒介温度, 控温精度: ±1度;
- 异常故障警示准确直接, LCD面板输出警报文本, 蜂鸣器提醒用户;
- 电气配电箱采用隔离设计, 散热好;
- 结构合理, 维修方便, 安装容易, 便于操作;
- H系列采用名牌泵浦, 压力大, 稳定性高, 无泄漏;
- H系列标准配置泵浦过载, 逆缺相保护, 液位保护, 超温保护, 等多项安全保护, 确保使用安全可靠;
- HT系列采用SPECK磁力驱动高温泵, 耐高温, 压力高, 性能稳定;
- HT系列标准配置泵浦过载, 逆缺相保护, 缺油保护, 超温保护, 超压保护等多项安全保护, 确保使用安全可靠;

### 选配项目:

- 可选配: 多口分放管、压力显示、回媒温度显示等要求;
- HLINK联网功能可选配;
- Multi-tube water row, pressure display, return media temperature display and other requirements can be optional
- HLINK networking function can be optional

### 注意事项 Note:

- 机器标准电压规格为: 3Φ 380V 50Hz.
- 机型的选择取决于所需的制热量。
- 客户如需定制特殊规格, 请与本公司联系确认。
- 产品规格若有变更, 恕不另行通知。
- The standard voltage is 3 Phase 380V 50Hz.
- Refer to the heating capacity to select the machine.
- Have any special needs, please contact us.
- We reserve right to change specifications without prior notice.





HGS 250

HGS

## HGS慢速粉碎机 LOW SPEED CRUSHER

HGS系列齿啃式粉碎机采用齿啃式刀具搭配切断刀之设计原理可以达到无粉尘的粉碎效果。该机器具备多重保护装置，操作安全。此系列适用于坚厚细长或韧性较强的水口料之立即回收粉碎。

HGS - AAA - BBB

取料方式  
空白 = 吸料盒配置  
D= 两料比例阀  
R= 人工集料盒  
AJ= 压缩空气 + 即回装置  
BJ= 气泵送料 + 即回装置

粉碎室宽度 (mm)  
华热慢速粉碎机

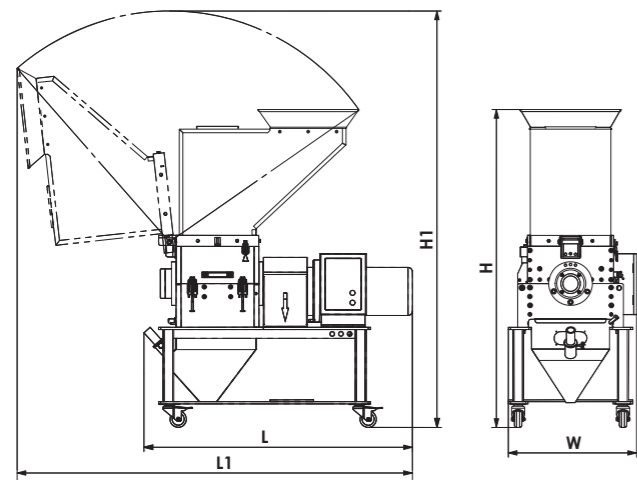

HGS

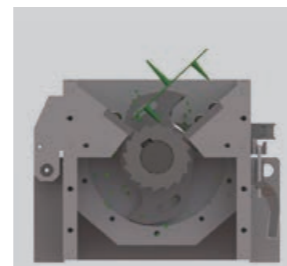

无筛网、无漏切削、颗粒度好，粉末极少  
None-screen, seamless cutting, particle size is good, little powder



低转速滚齿粉碎，上法兰加防尘条  
Low speed hobbing grinding, top flange with dust strip

## 规格表 Specifications

机 型	Type	HGS250	HGS250B	HGS350	HGS350B	HGS450	HGS450B
电机功率	Power(kw)	1.5	1.5	2.2	2.2	2.2	2.2
风机功率	Blower power(kw)	-	0.75	-	1.3	-	1.3
转速	Rotating speed(rpm)	20	20	20	20	20	20
爪刀	Claw tool	2	2	2	2	2	2
齿刀	Tooth tool	3	3	3	3	3	3
粉碎能力	Output(kg/hr)	10~15	10~15	13~20	13~20	20~30	20~30
重量	Weight(kg)	330	350	470	490	650	650
粉碎室尺寸	Crushing chamber(mm)	240X250	240X250	330X350	330X350	430X430	430X430
外形尺寸							
H	mm	1310	1310	1455	1455	1645	1645
H1	mm	1685	1685	1910	1910	2225	2225
W	mm	595	595	700	700	685	685
D	mm	1070	995	1230	1150	1310	1310
d1	mm	1540	1540	1760	1760	1990	1990



两料比例阀 (选配)  
Two material proportional valve (Optional)

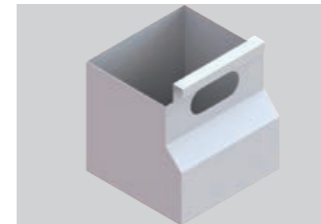

人工集料盒 (选配)  
Manual box (Optional)

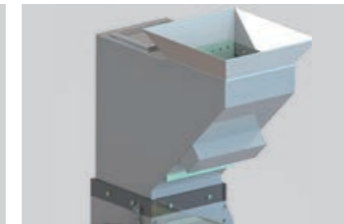

入料口加磁铁 (选配)  
Infeed with magnetic (Optional)

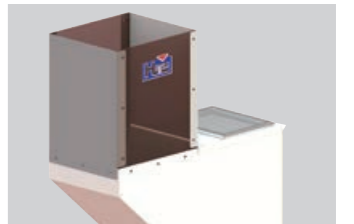

采用双层阻尼隔音材料 (加高口可选配)  
Double damping insulation materials (Heightening port Optional)



左/右防尘螺纹环  
Double side dust threaded ring



安全限位开关  
Safety limit switch

### 特点

- 采用优质减速电机，性能稳定，寿命长，传输扭矩大；
- 采用齿刀，爪刀一体设计粗粉碎和细粉碎同时进行，可立即与新料混合使用；
- 粉碎颗粒均匀，粉末含量少；
- 独特的传输设计使机器运行更平稳，噪音更低；
- 精密的设计，节省空间、清扫方便快捷；
- 更容易更换和保养电机。

### 注意事项Note:

- 机器标准电压规格为：3Φ 380V 50Hz。
- 最大粉碎能力取决于材料。
- 客户如需定制特殊规格，请于本公司联系确认。
- 产品规格若有变更，恕不另行通知。
- The standard voltage is 3 Phase 380V 50Hz.
- The max. output will be according to shape material.
- Have any special needs, please contact us.
- We reserve right to change specifications without prior notice.



HGS 250B



HGM 180-290

# HGM180

## HGM180中速粉碎机 MEDIUM SPEED CRUSHER

HGM180系列中速机边粉碎机适用于各种塑胶材料的粉碎再利用, 包括塑料边角料、浇口料之用, 适合软氧、尼龙、ABS等各种软硬塑料。该机结构紧凑、造型美观、操作方便、转动刀优化设计使能耗达到最小, 切削效率更高。

HGM - A A A - B B B - C C C

取料方式  
空白=吸料盒配置  
D=两料比例阀  
R=人工集料盒  
AJ=压缩空气+即回装置  
BJ=气泵送料+即回装置

粉碎室宽度(mm)  
粉碎回转直径(mm)  
华热中速粉碎机

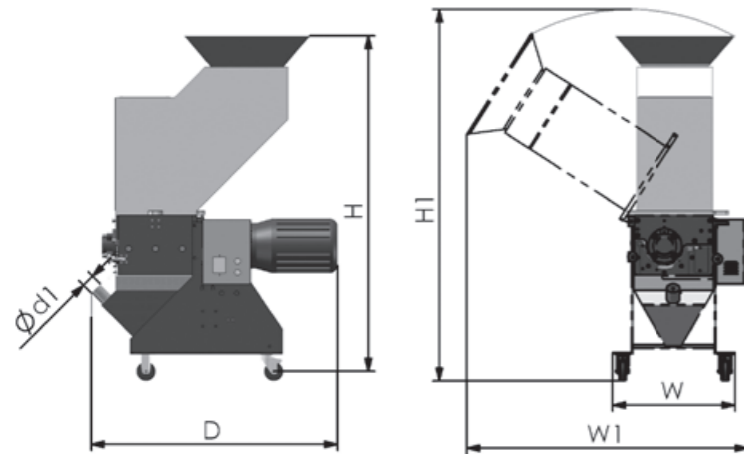

HGM180



HGM 180-220B

## 规格表 Specifications

机 型	Type	HGM180-220	HGM180-220B	HGM180-290	HGM180-290B
电机功率	Power(kw)	2.2	2.2	2.2	2.2
风机功率	Blower power(kw)	-	1.3	-	1.3
转速	Rotating speed(rpm)	150	150	150	150
动刀数	Rotor blades(Pcs)	24	24	30	30
定刀数	Fixed blades(Pcs)	2	2	2	2
粉碎能力	Output(kg/hr)	35~55	35~55	50~70	50~70
重量	Weight(kg)	180	190	200	210
投料口尺寸	Indeed opening(mm)	270X230	270X230	270X290	270X290
粉碎回转尺寸	Crushing rotary size(mm)	ø180X220	ø180X220	ø180X290	ø180X290
筛网孔径	Screen size(mm)	ø6	ø6	ø6	ø6
外形尺寸					
H	mm	1230	1230	1350	1350
H1	mm	1350	1350	1460	1460
W	mm	480	480	540	540
W1	mm	1060	1060	1060	1060
D	mm	880	880	975	975
Ød1	Inch	1.5	1.5	1.5	1.5

### 特点:

- 动刀呈V型阶梯排列, 粉碎物渐次进入, 切削平稳轻快。
- 主轴中速运转, 工作时噪音低, 粉尘少。
- 筛网托架拆装方便, 换网, 清料省时省力。
- 筛网托架进料斗打开后, 安全开关确保主轴不运转, 保证换网和清料时人身安全。
- 动刀用钝后, 只需修磨前刀面即可使用, 且安装时无需调整。
- 定刀反复使用四次后才需修磨。

### Special Features:

- Moving knife was V-shaped ladder arrangement, crushed material gradually into the cutting smooth and light.
- Spindle speed operation, low noise at work, less dust.
- Screen bracket easy disassembly, change the network, clean material save time and effort.
- After the screen tray or feed hopper is opened, the safety switch ensures that the spindle does not operate and ensures personal safety when changing the net and cleaning.
- After the knife with a blunt, just grinding the rake face can be used, and the installation without adjustment.
- Knife repeatedly used after four times to be grinding.

### 注意事项:

- 机器标准电压规格为: 3Φ 380V 50Hz。
- 最大粉碎能力取决于筛网孔径、材料等。
- 客户如需定制特殊规格, 请与本公司联系确认。
- 产品规格若有变更, 恕不另行通知。

### Note:

- The standard voltage is 3 Phase 380V 50Hz.
- The maximum crushing capacity depends on screen hole, material etc.
- Have any special needs, please contact us.
- We reserve right to change specifications without prior notice.



HGM 200-270B

# HGM200

## HGM200中速粉碎机 MEDIUM SPEED CRUSHER

HGM200中速机边粉碎机适用于各种塑胶材料的粉碎再利用，包括塑料边角料、浇口料之用，适合软氯、尼龙、ABS等各种软硬塑料。该机结构紧凑、造型美观、操作方便、转动刀优化设计使能耗达到最小，切削效率更高。

HGM - AAA - BBB - CCC

取料方式  
空白=吸料盒配置  
D=两料比例阀  
R=人工集料盒  
AJ=压缩空气+即回装置  
BJ=气泵送料+即回装置

粉碎室宽度(mm)  
粉碎回转直径(mm)  
华热中速粉碎机

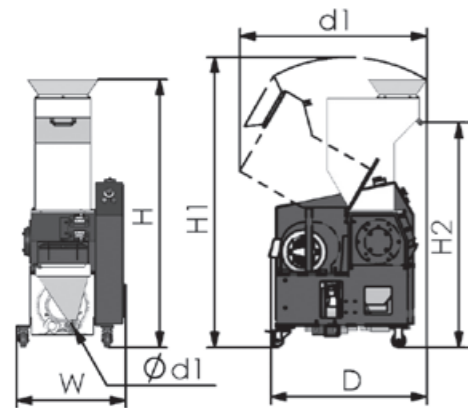

HGM200



HGM 200-270



HGM 200-270R

## 规格表 Specifications

机 型	Type	HGM200-270	HGM200-270B	HGM200-430	HGM200-430B
电机功率	Motor power(kW)	2.2	2.2	3	3
风机功率	Blower power(kw)	-	1.3	-	1.3
转速	Rotating speed(rpm)	328	328	328	328
动刀数	Rotor blades(Pcs)	6	6	6	6
定刀数	Fixed blades(Pcs)	2	2	2	2
粉碎能力	Output(kg/hr)	60-100	60-100	60-150	60-150
重量	Weight(kg)	270	270	330	330
投料口尺寸	Indeed opening(mm)	200X270	200X270	200X430	200X430
粉碎回转尺寸	Crushing rotary size(mm)	φ200X270	φ200X270	φ200X430	φ200X430
筛网孔径	Screen size(mm)	φ8	φ8	φ8	φ8
外形尺寸					
	Dimensions				
H	mm	1230	1230	1350	1350
H1	mm	1350	1350	1460	1460
W	mm	880	880	975	975
D	mm	480	480	540	540
d1	mm	1015	1015	1015	1015
φd2	Inch	1.5	1.5	1.5	1.5

### 特 点:

- 马达附有过负荷保护装置。
- 电源连锁保护系统，保障操作安全主电源隔离开关。
- 刀具由特殊钢制作而成，锋利、耐磨，粉碎颗粒均匀粉末少。
- 易拆式设计，清理维修方便快捷。
- 附有四轮，移动方便。

### Special Features:

- Motor overload protector.
- The chain safety device can protect the safety of operator and machine.
- The main power isolated switch.
- Cutter is made of special steel. so it is sharp, wearable and Crushing granule with little dust.
- Design for modularized structure, for easy cleaning and Maintenance.
- Four wheels for easy moving.

### 注意事项:

- 机器标准电压规格为: 3Φ 380V 50Hz。
- 最大粉碎能力取决于筛网孔径、材料等。
- 客户如需定制特殊规格，请与本公司联系确认。
- 产品规格若有变更，恕不另行通知。

### Note:

- The standard voltage is 3 Phase 380V 50Hz.
- The maximum crushing capacity depends on screen hole, material etc.
- Have any special needs, please contact us.
- We reserve right to change specifications without prior notice.



HFS 180

# HFS

## HFS机边粉碎机 EDGE CRUSHER

HFS系列机边粉碎机，适用于塑胶成型机旁与取出机或搭配皮带输送机将机边水口料或少量不良品粉碎，相比常规系列粉碎机其具备转速低，噪音低，产生粉尘少，操作简便的特点。

HFS - AAA - BBB

- 取料方式
- 空白 = 吸料盒配置
- D= 两料比例阀
- R= 人工集料盒
- AJ= 压缩空气 + 即回装置
- BJ= 气泵送料 + 即回装置

粉碎室宽度 (mm)

华热机边粉碎机

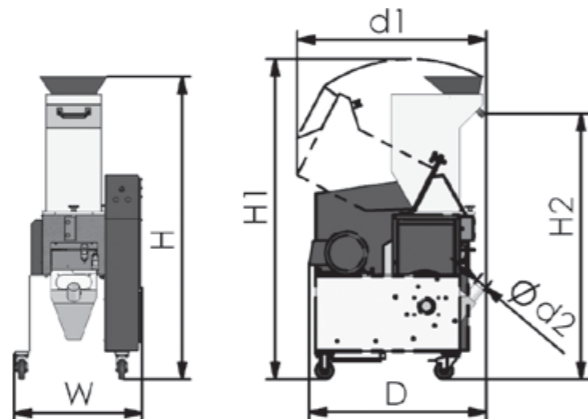

HFS

## 规格表 Specifications

机 型	Type	HFS180	HFS180-B
电机功率	Motor power(kW)	1.5/2.2	1.5/2.2
风机功率	Blower power(kw)	-	1.3
转速	Rotating speed(rpm)	355	355
动刀数	Rotor blades(Pcs)	3	3
定刀数	Fixed blades(Pcs)	2	2
粉碎能力	Output(kg/hr)	70~150	70~150
重量	Weight(kg)	200	220
投料口尺寸	Indeed opening(mm)	140X180	140X180
粉碎回转尺寸	Crushing rotary size(mm)	φ150 X 180	φ150 X 180
筛网孔径	Screen size(mm)	φ6	φ6
外形尺寸			
Dimensions			
H	mm	1250	1265
H1	mm	1325	1325
H2	mm	1070	1100
W	mm	530	530
D	mm	710	735
d1	mm	785	745
Φd2	Inch	1.5	1.5

### 特 点:

- 马达附有过负荷保护装置。
- 电源连锁保护系统，保障操作安全主电源隔离开关。
- 刀具由特殊钢制作而成，锋利、耐磨，粉碎颗粒均匀粉末少。
- 易拆式设计，清理维修方便快捷。
- 附有四轮，移动方便。

### Special Features:

- Motor overload protector.
- The chain safety device can protect the safety of operator and machine.
- The main power isolated switch.
- Cutter is made of special steel. so it is sharp, wearable and Crushing granule with little dust.
- Design for modularized structure, for easy cleaning and Maintenance.
- Four wheels for easy moving.

### 注意事项:

- 机器标准电压规格为: 3Φ 380V 50Hz。
- 最大粉碎能力取决于筛网孔径、材料等。
- 客户如需定制特殊规格，请与本公司联系确认。
- 产品规格若有变更，恕不另行通知。

### Note:

- The standard voltage is 3 Phase 380V 50Hz.
- The maximum crushing capacity depends on screen hole, material etc.
- Have any special needs, please contact us.
- We reserve right to change specifications without prior notice.



# HSS

## HSS粉碎机 GRANULATOR



HSS400

HSS系列粉碎机适用于破碎不同种类的软、硬塑胶，将块状、球状、条状以及水口料粉碎成颗粒。在塑胶行业中，对塑胶次品、废品、水口料的迅速加工回收起了重要作用，提高塑胶利用率。

HSS - AAA - BBB

取料方式  
空白 = 人工集料盒  
F = 风机送料

粉碎室宽度 (mm)

华热集中粉碎机

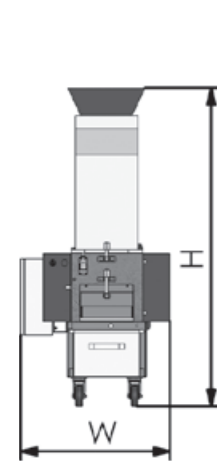

HSS180

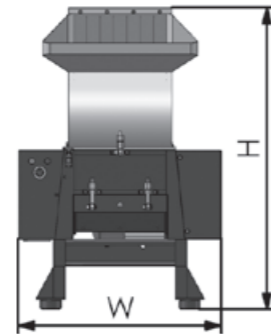
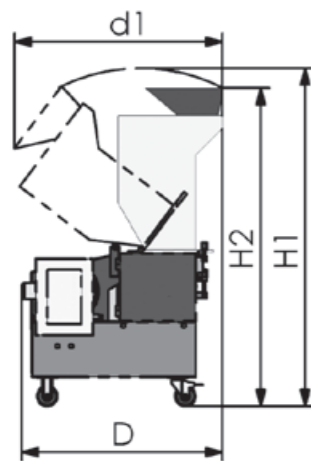

HSS230-800

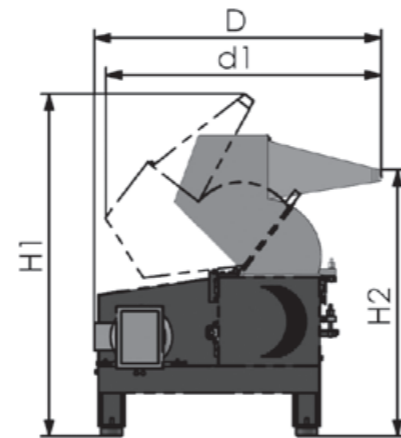

## 规格表 Specifications

机 型 Type	HSS180	HSS230	HSS300	HSS400	HSS500	HSS600	HSS800
电机功率 Motor power(kW)	2.2	4	5.5	7.5	11	15	22
转速 Rotating speed(rpm)	530	640	670	650	650	580	560
动刀数 Rotor blades(Pcs)	- A	6	9	12	15	18	24
	- B	3	3	3	3	6	6
定刀数 Fixed blades(Pcs)	2	2	2	2	2	4	4
粉碎能力 Output(Kg/hr)	75 ~ 150	100 ~ 200	200 ~ 300	350 ~ 500	400 ~ 580	450 ~ 600	600 ~ 800
重量 Weight(kg)	150	270	310	520	600	900	1640
入料口尺寸 Infeed opening(mm)	140×180	160×230	210×300	250×400	250×500	310×600	420×800
粉碎回转尺寸 Crushing rotary size(mm)	φ150×180	φ205×230	φ220×300	φ250×400	φ250×500	φ330×600	φ415×800
筛网孔径 Screen size(mm)	φ6	φ8	φ10	φ10	φ10	φ12	φ12
外形尺寸 Dimensions							
H(mm)	1160	1060	1195	1340	1345	1680	2130
H1(mm)	1235	1280	1280	1530	1530	1210	2290
H2(mm)	1160	970	1065	1190	1190	1485	1875
W(mm)	550	645	800	910	1010	1155	1440
D(mm)	735	960	1060	1310	1360	1370	1725
d1(mm)	760	785	920	1045	1036	1240	1050

### 特点

- HSS粉碎机标准可选A型平刀与B型片刀；
- 标准配备全钢刀片，增强耐磨可选配SKD11刀片材质；
- 800及以上机型标准配备轴承座水冷与推车移动集料箱；
- 标准配备有：过载保护、短路保护、进料斗打开停机保护；
- 风机送料旋风分离及二次除尘可选配

### Special Features

- HSS series granulator standard type A-type blade OR B-type blade;
- Standard with all-steel blade, enhanced wear-resistant SKD11 blade can be optional;
- 800 and above model with standard water-cooled bearing housing and cart collection bins;;
- Standard equipped with: overload protection, short circuit protection, hopper open shutdown protection;
- Fan feed cyclone separation and secondary dust can be optional

### 注意事项

- 机器标准电压规格为：3Φ 380V 50Hz。
- 最大粉碎能力取决于筛网孔径、材料等。
- 客户如需定制特殊规格，请与本公司联系确认。
- 产品规格若有变更，恕不另行通知。

### Note

- The standard voltage is 3 Phase 380V 50Hz.
- The maximum crushing capacity depends on screen hole, material etc.
- Have any special needs, please contact us.
- We reserve right to change specifications without prior notice.



HSS400F



# HNS

## HNS粉碎机 GRANULATOR



HNS400-800

HNS系列粉碎机适用于破碎不同种类的软、硬塑胶，将块状、球状、条状以及水口料粉碎成颗粒。在塑胶行业中，对塑胶次品、废品、水口料的迅速加工回收起了重要作用，提高塑胶利用率。

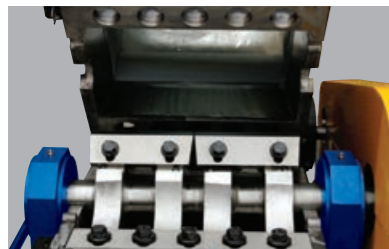
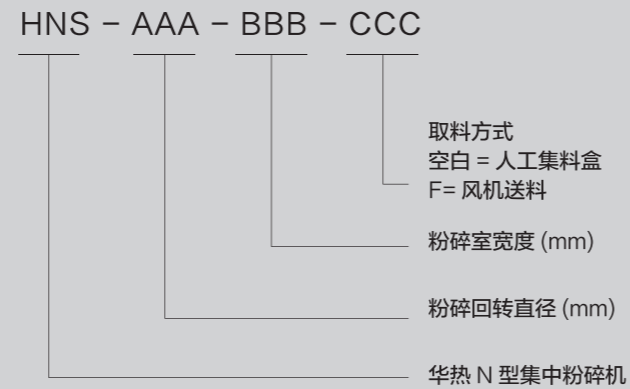

HNS260-400



HNS400-800

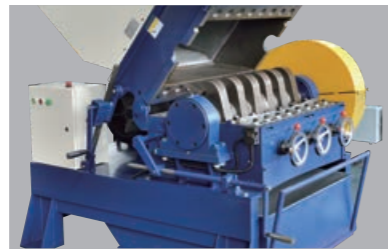

HNS400-800



HNS260-400

## 规格表 Specifications

机 型	Type	HNS260-400	HNS260-500	HNS260-600
电机功率	Motor power(kW)	7.5	11	11
转速	Rotating speed(rpm)	650	650	580
动刀数	Rotor blades(Pcs)	6	6	6
定刀数	Fixed blades(Pcs)	2	2	4
重量	Weight(kg)	460	540	600
入料口尺寸	Indeed opening(mm)	260×400	260×500	260×600
粉碎回转尺寸	Crushing rotary size(mm)	φ260×400	φ260×500	φ260×600
筛网孔径	Screen size(mm)	φ10	φ10	φ10
外形尺寸	Dimensions			
H(mm)		1420	1465	1460
H1(mm)		1510	1550	1550
H2(mm)		1190	1230	1230
W(mm)		855	915	1050
D(mm)		1270	1330	1375
d1(mm)		1365	1370	1370

机 型	Type	HNS400-600	HNS400-700	HNS400-800	HNS400-1000
电机功率	Power(kW)	15	18.5	22	30
转速	Rotating speed(rpm)	580	590	560	560
动刀数	Rotor blades(Pcs)	6	6	6	6
定刀数	Fixed blades(Pcs)	4	4	4	4
重量	Weight(kg)	1070	1190	1390	1590
入料口尺寸	Indeed opening(mm)	400×600	400×700	400×800	400×1000
粉碎回转尺寸	Crushing rotary size(mm)	φ400×600	φ400×700	φ400×800	φ400×1000
筛网孔径	Screen size(mm)	φ12	φ12	φ12	φ12
外形尺寸	Dimensions				
H(mm)		1940	1940	1990	2000
H1(mm)		2170	2170	2215	2230
H2(mm)		1590	1590	1640	1652
W(mm)		1190	1290	1435	1635
D(mm)		1830	1830	1840	1840
d1(mm)		1965	1965	1965	1965

### 特点

- 采用V型切削技术，减小刀具与粉碎腔磨损，提高刀具寿命；
- 采用调心滚子轴承，轴承外置结构，散热良好；
- 粉碎腔采用中部半开结构；
- 筛网下部全开放并采用摇杆开启结构；
- 采用全封闭式带轮安全护罩
- 粉碎室机械开启，省力安全。

### 注意事项

- 机器标准电压规格为：3Φ 380V 50Hz。
- 最大粉碎能力取决于筛网孔径、材料等。
- 客户如需定制特殊规格，请与本公司联系确认。
- 产品规格若有变更，恕不另行通知。

### Note:

- The standard voltage is 3 Phase 380V 50Hz.
- The maximum crushing capacity depends on screen hole, material etc.
- Have any special needs, please contact us.
- We reserve right to change specifications without prior notice.

### Special Features

- Using "V type" cutting technology ,decrease abrasion between blades and crushing chamber ,improve service life of blades .
- Using spherical roller bearings, bearing housing external structure, good heat dissipation.
- Crushing chamber use half-open structure .
- The bottom of screen open and rocker open structure .
- Using all close safety covers with wheels .
- Cutting chamber open by mechanical, saving and safety, optional

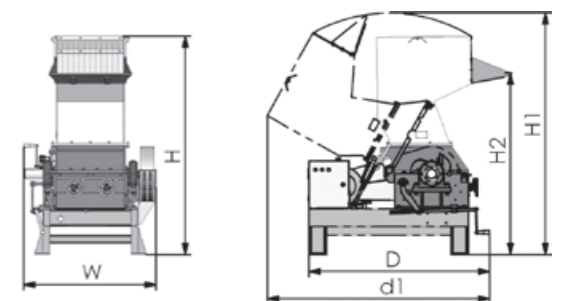



HZS400-800F

# HZS400

## HZS400强力粉碎机 HIGH PERFORMANCE GRANULATOR

HZS系列粉碎机适用于各种塑料、橡胶、织物、皮革、硬纸板、木材及铝箔的粉碎，粉碎物外形可以是薄膜、片状、管状、浇口料及各类中空容器。当粉碎量较大时，可以配置喂料输送机，吸料风机，储料仓及除尘系统。

HZS - AAA - BBB - CCC

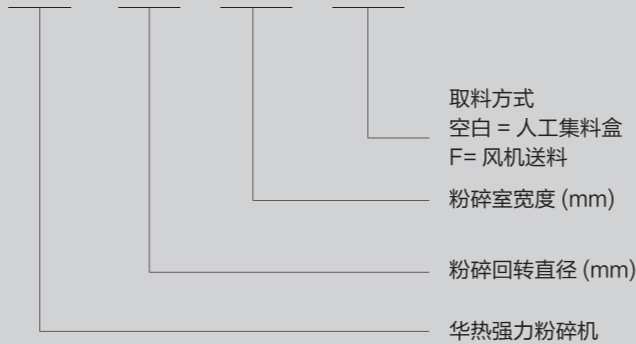

HZS400-800

## 规格表 Specifications

机 型 Type	HZS400-800	HZS400-800F
电机功率 Motor power(kW)		30
动刀数 Rotor blades(Pcs)		6
定刀数 Fixed blades(Pcs)		4
粉碎回转尺寸 Crushing rotary size(mm)		φ400×800
投料口尺寸 Infeed opening(mm)		400×800
筛网孔径 φ d(mm)		φ12
驱动装置 Drive device		手摇/Handle
驱动单元功率 Drive unit power(kW)	-	2.2
外形尺寸 Dimensions		
H(mm)	2105	
H1(mm)	2225	
H2(mm)	1750	
W(mm)	1500	
D(mm)	1620	
d1(mm)	2435	

### 特点

- 机体采用钢结构，刚性强，具有良好的抗冲击性。
- 主轴系统经过平衡处理，机器运转稳定可靠。
- 动定刀均采用V型切削技术，减小刀具与粉碎腔磨损，提高刀具寿命；
- 采用调心滚子轴承，轴承外置结构，散热良好；
- 根据不同材料的粉碎要求，主轴上的动刀可以设计成3组或5组。
- 可选配惯性飞轮，提高切削强度。

### Special Features

- Rigid steel body to be resistant to impact.
- Balanced main shaft to ensure safely smoothly running.
- Dual V-cutting geometry to minimize friction between crushing material and both interior sidewalls ,improve service life of blades .
- Using spherical roller bearings, bearing housing external structure, good heat dissipation.
- 3 groups or 5 groups of rotors available depending on different crushing material
- Optional inertia flywheel to improve cutting strength .

### 注意事项

- 机器标准电压规格为：3Φ 380V 50Hz。
- 最大粉碎能力取决于筛网孔径、材料等。
- 客户如需定制特殊规格，请与本公司联系确认。
- 产品规格若有变更，恕不另行通知。

### Note:

- The standard voltage is 3 Phase 380V 50Hz.
- The maximum crushing capacity depends on screen hole, material etc.
- Have any special needs, please contact us.
- We reserve right to change specifications without prior notice.

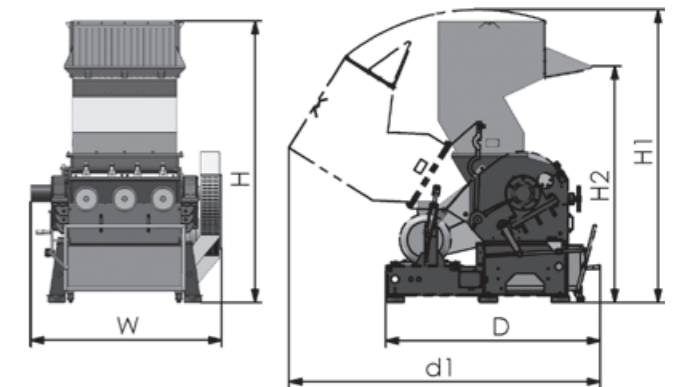



HZS600-1200F

# HZS600

## HZS600强力粉碎机 HIGH PERFORMANCE GRANULATOR

HZS系列粉碎机适用于各种塑料、橡胶、织物、皮革、硬纸板、木材及铝箔的粉碎，粉碎物外形可以是薄膜、片状、管状、浇口料及各类中空容器。当粉碎量较大时，可以配置喂料输送机，吸料风机，储料仓及除尘系统。

HZS - AAA - BBB - CCC

取料方式  
空白 = 人工集料盒  
F = 风机送料

粉碎室宽度 (mm)

粉碎回转直径 (mm)

华热强力粉碎机



HZS600-1200F



HZS600-800F

## 规格表 Specifications

机 型 Type	HZS600-800F	HZS600-1000F	HZS600-1200F
电机功率 Motor power(kW)	37	45	55
动刀数 Rotor blades(Pcs)	2×3 OR 2×5	2×3 OR 2×5	2×3 OR 2×5
定刀数 Fixed blades(Pcs)	2×2	2×2	2×2
粉碎回转尺寸 Crushing rotary size(mm)	φ600×800	φ600×1000	φ600×1200
投料口尺寸 Indeed opening(mm)	600×800	600×1000	600×1200
筛网孔径 φ d(mm)	φ12	φ12	φ12
驱动装置 Drive device	电动/ Electric	液压/Hydraulic	液压/Hydraulic
驱动单元功率 Drive unit power(kW)	0.75 (Electric)	2.2 (Hydraulic)	2.2 (Hydraulic)
外形尺寸 Dimensions			
H(mm)	2900	2900	2900
H1(mm)	3143	3143	3143
H2(mm)	2198	2198	2198
W(mm)	1620	1820	2020
D(mm)	2160	2230	2230
d1(mm)	2680	2680	2680

### 特点

- 机体采用钢结构，刚性强，具有良好的抗冲击性。
- 主轴系统经过平衡处理，机器运转稳定可靠。
- 采用V型切削技术，减小刀具与粉碎腔磨损，提高刀具寿命；
- 采用调心滚子轴承，轴承外置结构，散热良好；
- 根据不同材料的粉碎要求，主轴上的动刀可以设计成3组或5组。
- 可选配惯性飞轮，提高切削强度。

### Special Features

- Rigid steel body to be resistant to impact.
- Balanced main shaft to ensure safely smoothly running.
- Using V-cutting geometry to minimize friction between crushing material and both interior sidewalls ,improve service life of blades .
- Using spherical roller bearings, bearing housing external structure, good heat dissipation.
- 3 groups or 5 groups of rotors available depending on different crushing material
- Optional inertia flywheel to improve cutting strength .

### 注意事项

- 机器标准电压规格为：3Φ 380V 50Hz。
- 最大粉碎能力取决于筛网孔径、材料等。
- 客户如需定制特殊规格，请与本公司联系确认。
- 产品规格若有变更，恕不另行通知。

### Note:

- The standard voltage is 3 Phase 380V 50Hz.
- The maximum crushing capacity depends on screen hole, material etc.
- Have any special needs, please contact us.
- We reserve right to change specifications without prior notice.

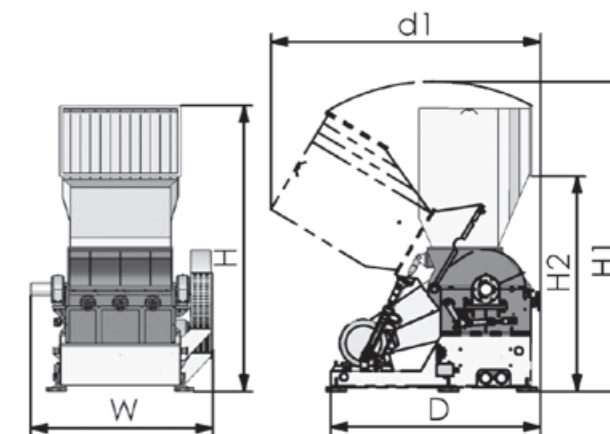





HZSH700-1000F

# HZSH

## HZSH重型粉碎机 HEAVY DUTY GRANULATOR

HZSH列粉碎机适用于各种塑料、橡胶、织物、皮革、硬纸板、木材及铝箔的粉碎，粉碎物外形可以是薄膜、片状、管状、浇口料及各类中空容器。当粉碎量较大时，可以配置喂料输送机，吸料风机，储料仓及除尘系统。

HZSH - AAA - BBB - CCC

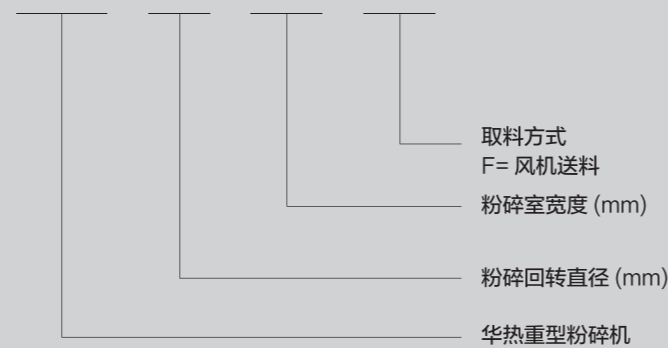

辅助定刀装置 (选配)  
Auxiliary fixed blades device  
(Optional)

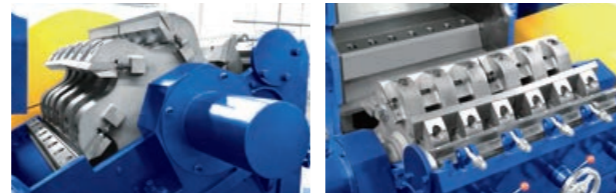

HZSH700-1000

## 规格表 Specifications

机 型 Type	HZSH700-1000F
电机功率 Motor power(kW)	90 OR 110
动刀数 Rotor blades(Pcs)	2 × 7
定刀数 Fixed blades(Pcs)	2
粉碎回转尺寸 Crushing rotary size(mm)	φ700 × 985
投料口尺寸 Indeed opening(mm)	985x1000
筛网孔径 φ d(mm)	φ12
驱动装置 Drive device	液压/Hydraulic
风机功率 Blower power(kW)	7.5 OR 11
<b>外形尺寸 Dimensions</b>	
H(mm)	3545
H1(mm)	3830
H2(mm)	2325
W(mm)	2045
D(mm)	2590
d1(mm)	3535

### 特点

- 机体采用钢结构，刚性强，具有良好的抗冲击性。
- 主轴系统经过平衡处理，机器运转稳定可靠。
- 采用V形切削技术，切削时工作物从两侧向中心滑动，减少机器两侧壁之摩擦。
- 根据不同材料的粉碎要求，主轴上的动刀可以设计成5或7。
- 轴承安装在机体外部，粉尘或水不容易侵入，散热良好，保养及维修简便易行。
- 配置双缸液压驱动装置，维护清理更加便捷。
- 可选配惯性飞轮，提高切削强度。
- 根据不同材料要求，可选配辅助定刀。

### 注意事项

- 机器标准电压规格为：3φ 380V 50Hz。
- 最大粉碎能力取决于筛网孔径、材料等。
- 客户如需定制特殊规格，请与本公司联系确认。
- 产品规格若有变更，恕不另行通知。

### Note:

- The standard voltage is 3 Phase 380V 50Hz.
- The maximum crushing capacity depends on screen hole, material etc.
- Have any special needs, please contact us.
- We reserve right to change specifications without prior notice.

### Special Features

- Rigid steel body to the resistant to impact.
- Balanced main shaft to ensure safely smoothly running.
- Using V-cutting geometry to minimize friction between crushing material and both interior sidewalls ,improve service life of blades .
- 5groups or 7groups of rotors available depending on different crushing material.
- Using spherical roller bearings, bearing housing external structure, good heat dissipation.
- 3 groups or 5 groups of rotors available depending on different crushing material
- Standard with cylinder hydraulic drive, maintenance and cleaning more convenient.
- Optional inertia flywheel to improve cutting strength .
- Optional auxiliary knife, according to the different material requirements ,is more suitable for wall thickness product.

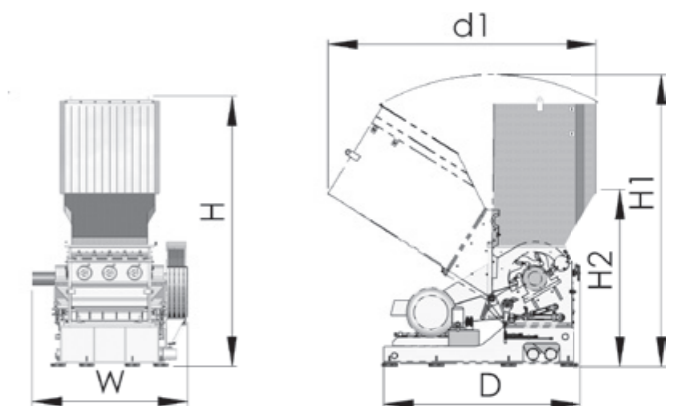



# HSP

## HSP管材粉碎机 PIPE MATERIAL GRANULATOR

适用于较长的管材或型材的粉碎回收，避免采用常规机台时需要挖坑搭台的苦恼，专用高效。



HSP600-600F

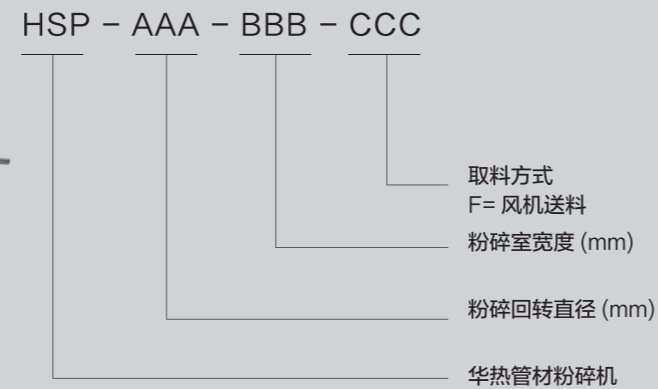

HSP400-500F



HSP400-500F



HSP600-600F

## 规格表 Specifications

机 型 Type	HSP400-500F	HSP600-600F
电机功率 Motor power(kW)	15	30 OR 45
动刀数 Rotor blades(Pcs)	2 × 3	2 × 3 OR 2 × 5
定刀数 Fixed blades(Pcs)	4	4
粉碎回转尺寸 Crushing rotary size(mm)	φ 400 × 500	φ 600 × 600
筛网孔径 φd(mm)	φ12	φ12
驱动装置 Drive device	手摇/Handle	液压/Hydraulic
外形尺寸		
H(mm)	1295	1740
H1(mm)	2230	2840
H2(mm)	960	1125
W(mm)	1100	1305
D(mm)	1745	2200

### 特 点

- 机体采用钢结构，刚性强，具有良好的抗冲击性。
- 主轴系统经过平衡处理，机器运转稳定可靠。
- 采用双V剪刀式切削，能耗小、剪切热少，适用于塑料热敏性高的料品，粉碎粒度均匀。
- 轴承安装在机体外部，粉尘或水不容易侵入，散热良好，保养及维修简便易行。
- 特殊设计的投料斗形式，低矮平斜，便于较长管材型材的送入。
- 针对平扁的板材或片材，可特殊设计投料斗形式。



### Special Features

- Rigid steel body to be resistant to impact.
- Balanced main shaft to ensure safely smoothly running.
- Dual V-cut technology. small energy consumption. Less shear heat. Suitable plastic materials in the high heat-sensitive materials. particle size uniformity.
- Using spherical roller bearings, bearing housing external structure, good heat dissipation.
- Specially designed hopper. low level ramp to facilitate long pipes and profiles into the hopper.
- Can specially design the hopper for the flat sheet.

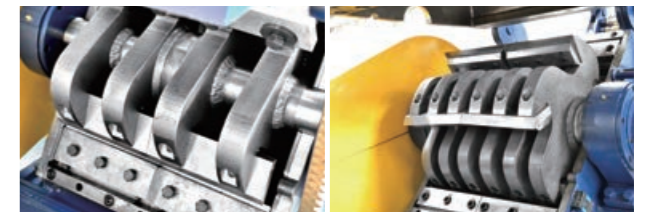

HSP400-500F

HSP600-600F

### 注意事项

- 机器标准电压规格为：3Φ 380V 50Hz。
- 最大粉碎能力取决于筛网孔径、材料等。
- 客户如需定制特殊规格，请与本公司联系确认。
- 产品规格若有变更，恕不另行通知。

### Note:

- The standard voltage is 3 Phase 380V 50Hz.
- The maximum crushing capacity depends on screen hole, material etc.
- Have any special needs, please contact us.
- We reserve right to change specifications without prior notice.

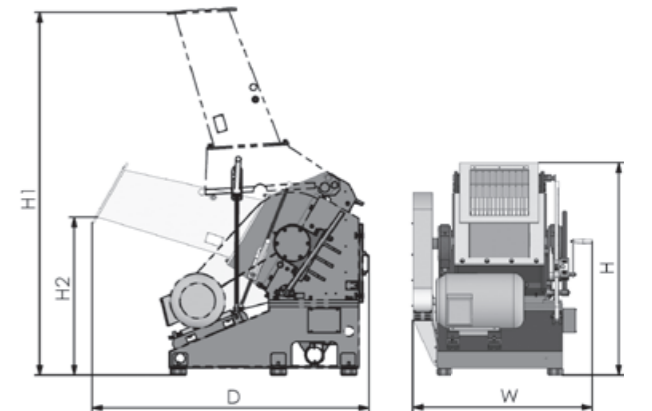



HTS600-800F

HTS

## HTS桶体粉碎机 BARREL GRANULATOR

HTS系列粉碎机适用于各种各种塑料桶体等中空容器的粉碎再利用, 包括饮用水桶、油脂桶等。该结构紧凑, 操作方便, 双V切削的专业设计使能耗达到最小切削效率更高。

HTS - AAA - BBB - CCC

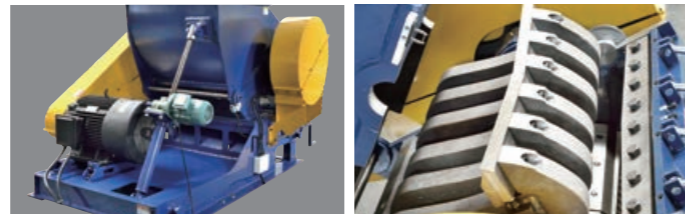
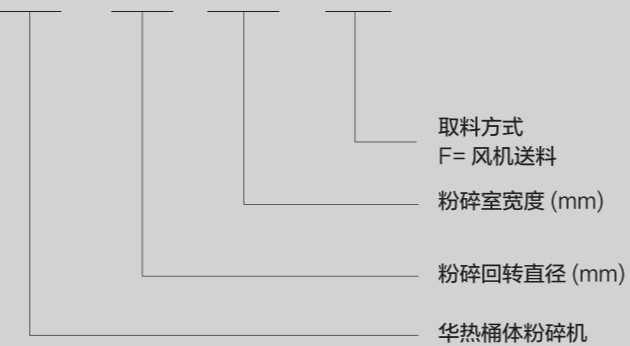

## 规格表 Specifications

机 型 Type	HTS600-800F	
电机功率 Motor power(kW)	30	45
动刀数 Rotor blades(Pcs)	2 × 3 OR 2 × 5	
定刀数 Fixed blades(Pcs)	4	
粉碎回转尺寸 Crushing rotary size(mm)	φ600 × 800	
投料口尺寸 Indeed opening	1080 × 806	
筛网孔径 φ d(mm)	φ12	
驱动装置 Drive device	减速电机/Gear	
驱动电机功率 Drive power(kW)	0.75	
外形尺寸 Dimensions		
H(mm)	3170	
H1(mm)	3330	
H2(mm)	2040	
W(mm)	1620	
D(mm)	2340	
d1(mm)	3060	

### 特点

- 采用双V剪刀式切削, 能耗小、剪切热少, 粉碎颗粒均匀, 剪切效率高;
- 轴承安装在机体外部, 粉尘或水不容易侵入, 散热良好, 保养及维修简便易行。
- 特殊进料箱转向设计, 可以更好的保证圆形物料实现输送上料并自动转向, 提高喂料效率;
- 粉碎上体的弧形内腔设计, 有效保证抓料、粉碎大容量的腔体产品更为高效;
- 采用电动螺旋快速打开粉碎室内部, 方便维护动刀和定刀, 同时可以快速完成粉碎室腔体的清理;
- 主轴系统经过平衡处理, 机器运转稳定可靠。
- 轴承安装在机体外部, 粉尘或水不容易侵入, 散热良好, 保养及维修简便易行。
- 可选配惯性飞轮, 提高切削强度;

### 注意事项

- 机器标准电压规格为: 3Φ 380V 50Hz。
- 最大粉碎能力取决于筛网孔径、材料等。
- 客户如需定制特殊规格, 请与本公司联系确认。
- 产品规格若有变更, 恕不另行通知。

### Note:

- The standard voltage is 3 Phase 380V 50Hz.
- The maximum crushing capacity depends on screen hole, material etc.
- Have any special needs, please contact us.
- We reserve right to change specifications without prior notice.

### Special Features

- Dual V-cut technology. small energy consumption, less shear hear, particle size uniformity, cutting efficiency is higher.
- Using spherical roller bearings, bearing housing external structure, good heat dissipation.
- Special feeding box steering design, can better ensure the circle material conveying and automatic steering, improve the feed efficiency.
- Crushing chamber upper baby arc cavity design, ensuring the effective grab materials, crushing the large capacity of the hollow products more efficient.
- Using electric screw quickly open crushing chamber department, conveniently to maintain the moving blade and fixed blade, also can quickly completed cleaning the curding chamber.
- Balanced main shaft to ensure safely smoothly running.
- Optional inertia flywheel to improve cutting strength .

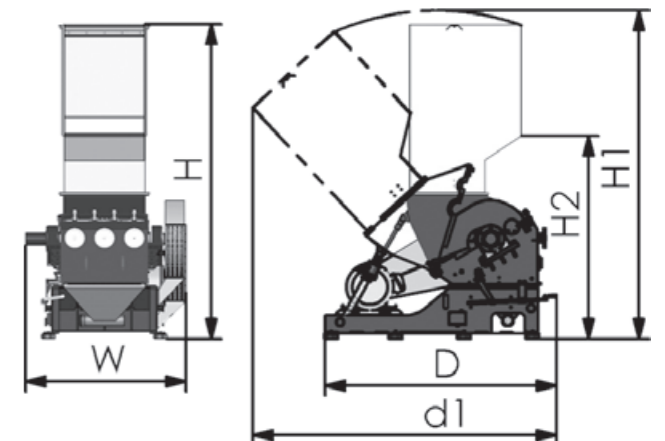



# HTP

## HTP托盘粉碎机 TRAY MATERIAL GRANULATOR

适用于托盘、管材及宽幅型材粉碎回收，免除采用常规机台对制品预分解的工序，减少原料降解，节省人工，减少劳动强度，提高粉碎回收效率。

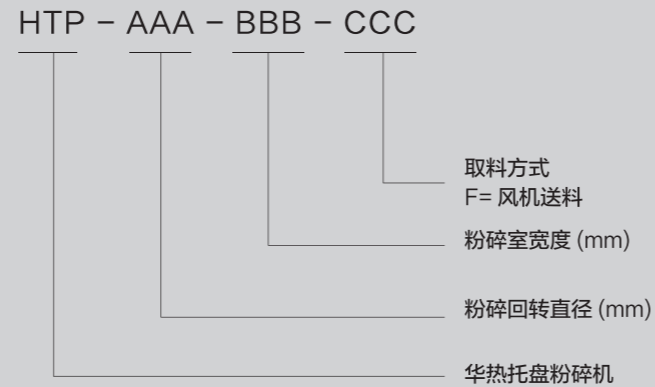

HTP800-1200F

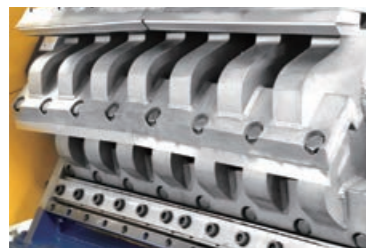

七爪刀架  
Seven groups rotor



五爪刀架  
Five groups rotor



## 规格表 Specifications

机 型	HTP800-1200F
电机功率 Motor power(kW)	75 OR 110
动刀数 Rotor blades(Pcs)	2 × 5 OR 2 × 7
定刀数 Fixed blades(Pcs)	4
粉碎回转尺寸 Crushing rotary size(mm)	φ800 × 1200
投料口尺寸 Indeed opening	360 × 1200
筛网孔径 φ d(mm)	φ12
驱动装置 Drive device	液压/Hydraulic
驱动电机功率 Drive power(kW)	2.2
外形尺寸	
H(mm)	2050
H1(mm)	3550
H2(mm)	1550
W(mm)	2350
D(mm)	2800

### 特点

- 采用双V剪刀式切削，能耗小、剪切热少，粉碎颗粒均匀，剪切效率高；
- 轴承安装在机体外部，粉尘或水不容易侵入，散热良好，保养及维修简便易行。
- 通过液压系统轻松实现粉碎室及筛网开合，维护保养非诚勿扰，同时也可以快速的完成对粉碎室的清理；
- 特殊的投料形式，低矮平斜，便于托盘及宽幅型材的送入；
- 针对不同的物料，我们可以提供最优化的喂料方案；
- 主轴系统经过平衡处理，机器运转稳定可靠；
- 可选配惯性飞轮，提高切削强度；

### Special Features

- Dual V-cut technology. small energy consumption, less shear heat, particle size uniformity, cutting efficiency is higher.
- Using spherical roller bearings, bearing housing external structure, good heat dissipation.
- Using the hydraulic system easily crushing chamber and screen opening, maintenance is convenient but also non honest, rapid completion of the crushing chamber cleaning.
- Special form of feeding, low flat inclined, is advantageous for the tray and into wide profile
- In view of the different materials, we can provide optimal feeding scheme.
- Balanced main shaft to ensure safely smoothly running.
- Optional inertia flywheel to improve cutting strength .

### 注意事项

- 机器标准电压规格为: 3Φ 380V 50Hz.
- 最大粉碎能力取决于筛网孔径、材料等。
- 客户如需定制特殊规格，请与本公司联系确认。
- 产品规格若有变更，恕不另行通知。

### Note:

- The standard voltage is 3 Phase 380V 50Hz.
- The maximum crushing capacity depends on screen hole, material etc.
- Have any special needs, please contact us.
- We reserve right to change specifications without prior notice.

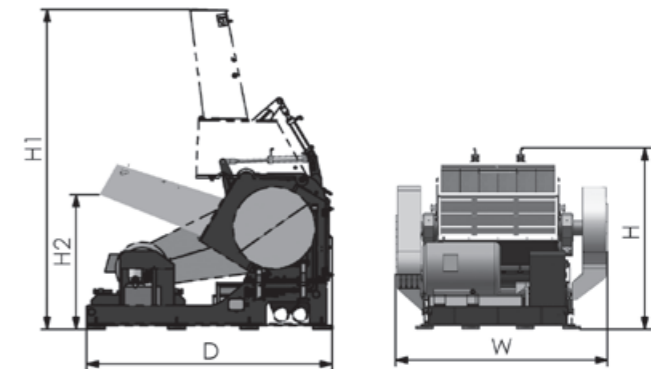



# HSM

## HSM撕碎机 POWERFUL SHREDDER



HSM 12045

适用于特厚、韧性、大型塑料材料，(如浇口料、大型塑料管材、叉车托板、塑料薄膜、纤维、纸张、木头等)的有效粉碎，在不降解物料原性的情况下将浇口料或塑料废品撕碎，从而进一步粉碎利用。可应用于解决废家电/大块料/PE管材/橡胶轮胎/包装材料回收利用。

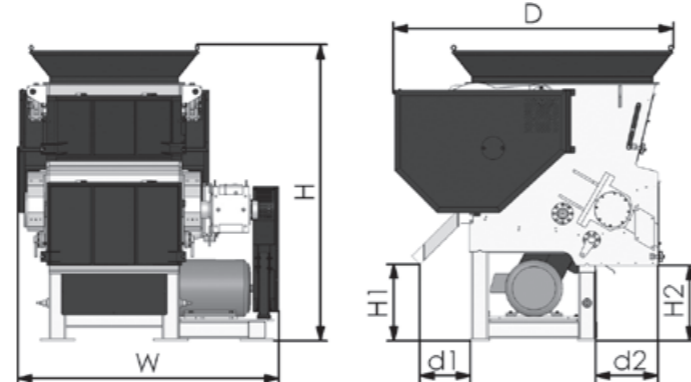
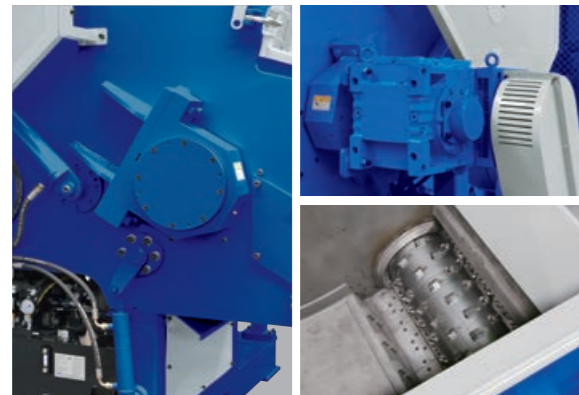
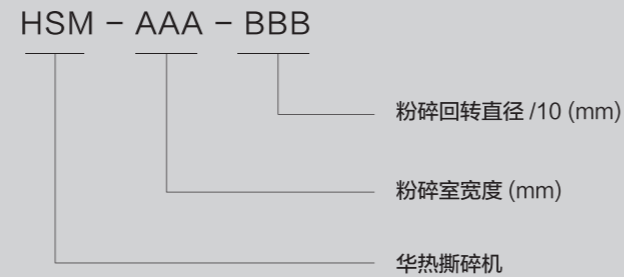

## 规格表 Specifications

机 型 Type	HSM 12045
转速 Rotating speed (rpm)	75
电机功率 Motor power(kW)	55
动刀数 Rotor blades(Pcs)	81
定刀数 Fixed blades(Pcs)	8
回转直径 Rotor diameter(mm)	φ 455
粉碎腔尺寸 Crushing chamber size(mm)	800 × 1010
筛网孔径 Screen size c d(mm)	φ 40 ~ φ100
驱动装置 Drive device	液压/Hydraulic
驱动电机功率 Drive power(kW)	5.5
重量 Weight(kg)	5500
外形尺寸 Dimensions	
H(mm)	2585
H1(mm)	670
H2(mm)	680
W(mm)	2280
D(mm)	2445
d1(mm)	435
d2(mm)	530

### 特点

- 采用柔和铣削式粉碎，噪音低、能耗小、粉碎粒度均匀。
- 动刀片按照数控车刀片设计，可旋转调换四次使用，使用方便、寿命长。
- 采用高性能液力联轴装置直联电机，在启动及粉碎全过程保护电机不超载工作
- 有效保护电机、减速机齿轮箱、转子刀轴等零部件，提升整机性能及安全性。
- 减速机齿轮箱(德国)、液压泵站(意大利)、主要控制电器件 均采用进口名牌。
- 采用高性能PLC触摸屏人机接口控制，轻松实现设备全自动运转，操作简单 使用方便。

### Special Features

- Use of soft milling-type grinding, low noise, small power, particle size uniformity.
- The blades can rotary exchange four times to use, easy and long life.
- Using high-performance hydraulic coupling device. Protect the motor, reduction gear box, rotor blade shaft and other components, to enhance overall performance and safety.
- Reduction gear box (Germany), hydraulic pump station(Italy),the main control electrical parts adopt imported famous brand.
- High-performance PLC control HMI touch screen, easy operation with full automation, simple operation, easy to use.

### 注意事项

- 机器标准电压规格为: 3Φ 380V 50Hz。
- 最大粉碎能力取决于筛网孔径、材料等。
- 客户如需定制特殊规格，请与本公司联系确认。
- 产品规格若有变更，恕不另行通知。

### Note:

- The standard voltage is 3 Phase 380V 50Hz.
- The maximum crushing capacity depends on screen hole, material etc.
- Have any special needs, please contact us.
- We reserve right to change specifications without prior notice.