

Technical Data Sheet



PB471 SERIES POWER TAKE-OFF

Product Features

Rear Mount Hotshift PTO for ZF

The 471 series is designed for certain ZF transmissions with rear openings, it has an output ratio suitable for high torque in critical applications.

Built with constant mesh gearing, this PTO incorporates a clutch pack to engage and disengage the output shaft.

Suits:

ZF ASTRONIC transmissions.
(Refer to the eGuide Configurator on www.hydreco.com for confirmation and details)

- **Output Speeds 96 to 182% of Engine Speed (Transmission Dependant)**
Giving good output values for all applications.
- **Standard Outputs**
For flexibility in applications
- **Non Standard Rear Mount**
To provide extra torque output.
- **Deep Groove Ball Bearings**
For longer life and higher performance.
- **Hotshift with Pneumatic Engagement**
Can engage 'on the run' - no need for clutch operation with manual gearboxes.

POWAUTO

DAVID BROWN
HYDRAULICS

HYDRECO

HYDRECO
POWAUTO
HYDRAULIC SOLUTIONS PROVIDER

www.hydreco.com

Technical Data Sheet

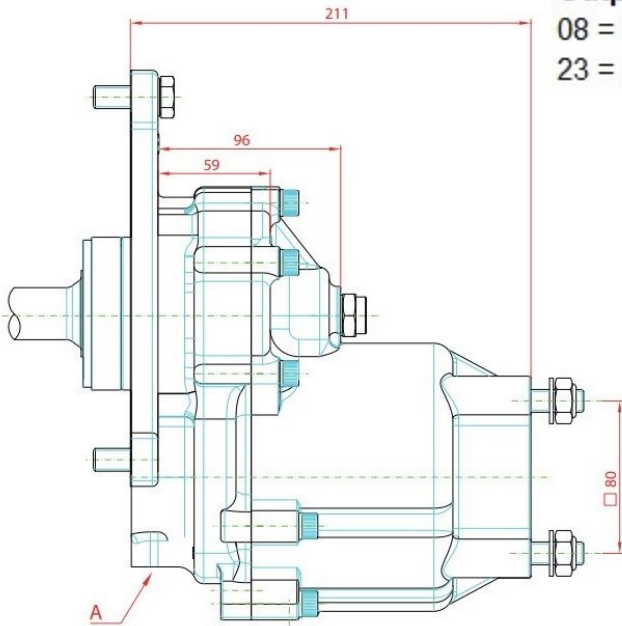
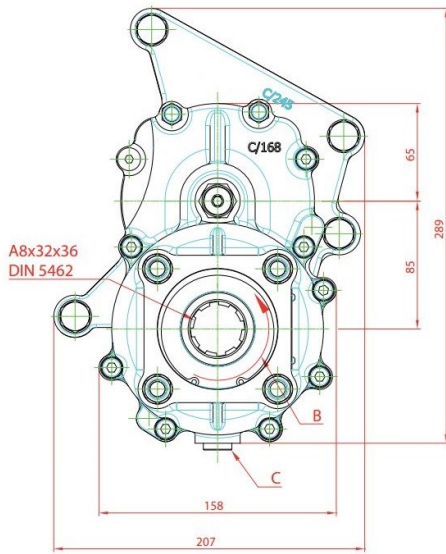

PTO DESIGNATION CODES

471 Series

PB 471 A 23

Identifier

PB = PTO Rear Mount

PTO Series

471

Engagement Type

A = Air

Output Type

08 = 8T Powauto Hydraulic Spline

23 = 8T Ø36 DIN 5462 Spline - Female and DIN Mount

Technical Specifications		
Ratings		
Torque	Nm / ft.lb	400 / 295
Power @ 500 rpm	kW / hp	20.9 / 28.1
Power @ 1000 rpm	kW / hp	41.9 / 56.1
Output Shaft Rotation		Same as Engine
Approximate Bare Mass	kg / lb	23.4 / 51.5
Mounting Kit		Included

Note: For full details refer to the owners manual or the eGuide configurator found at www.hydreco.com/markets/transport

DISTRIBUTOR:

Doc: PB471—03/17

POWAUTO

DAVID BROWN
HYDRAULICS

HYDRECO

HYDRECO
POWAUTO
HYDRAULIC SOLUTIONS PROVIDER

www.hydreco.com