

Horizontal End-Suction Pumps

SBA601...604

Axial/semi-open impellers

SBA601...604

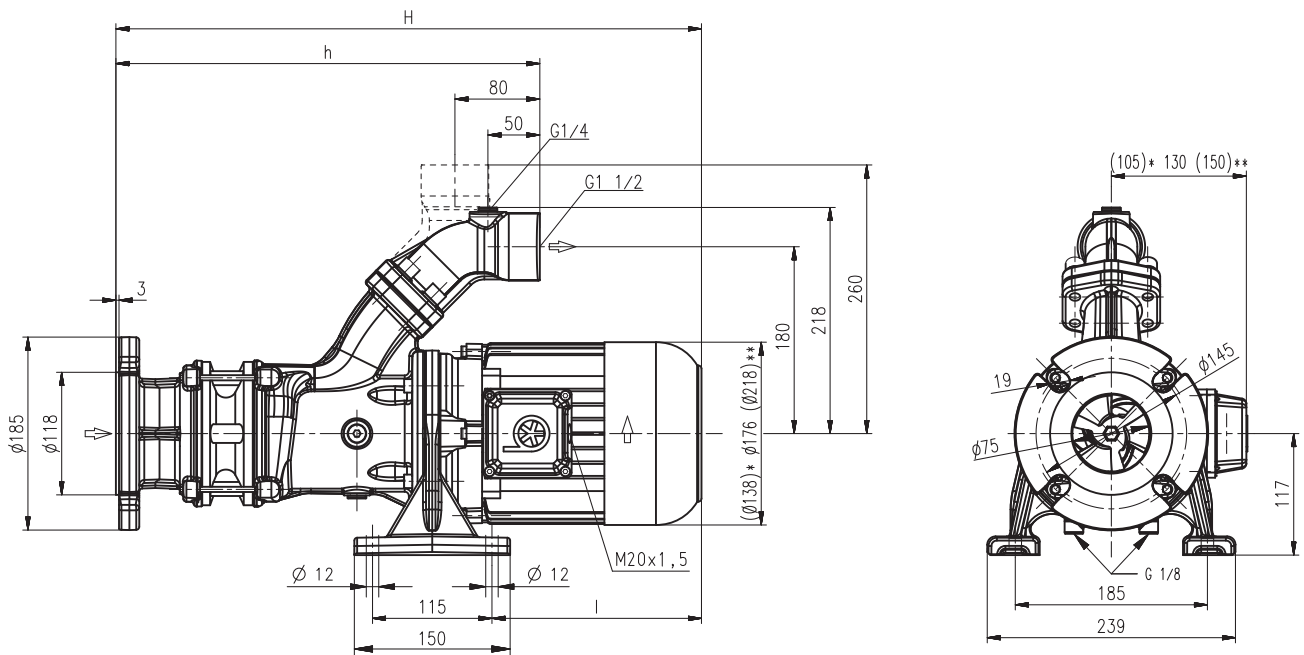

*) Dimensions for SBA601
 **) Dimensions for SBA603, 604

Type	Vol. del. at manom. del. head l/min / m	Dimensions		Length l mm	Weight kg	Power kW	Voltage 3 ~ V	Fre- quen- cy Hz	Current A	Speed 1/min
		H mm	h mm							
SBA601	300/6	524	360	211	32	1.1	220-240 380-415	50 50	4.33 2.50	2850 2850
SBA602	300/16	666	424	289	46	1.27	460	60	2.4	3440
SBA603	300/25	769	488	328	61	2.2	220-240 380-415	50 50	7.8 4.5	2890 2890
SBA604	300/35	863	552	358	70	2.55	460	60	4.4	3480
						3.3	220-240 380-415	50 50	11.6 6.7	2930 2930
						3.8	460	60	6.4	3520
						5.0	220-240 380-415	50 50	17.3 10.0	2920 2920
						5.75	460	60	9.5	3520

Horizontal End-Suction Pumps

are centrifugal inline pumps with a compact design where the impeller is mounted onto the extended motor shaft. These pumps are not self-priming and must be gravity fed. All pumps are equipped with a single mechanical seal. Upon request a second mechanical seal is available to allow for dry-running (-GD). This pump series is designed for horizontal installations next to a tank and for pumping **air entrained coolant** fluids, such as **water-soluble coolants or cutting oils**, as they occur in **high speed turning, milling or grinding applications**. The SBA pumps are equipped with the user-friendly **(SAE) flange** connection which allows for either vertical or horizontal pipe connection and the connection of a pressure gauge with G 1/4. For more information see mechanical features within the technical information section.



Applications

Types of fluid
coolants
cooling/cutting oils
Kinematic viscosity
...45 mm²/s (45 cSt)
Pumping temperature
0...80° C

Construction

Pump body	cast iron
Cover	cast iron
Impeller axial	cast steel
Impeller radial	cast steel
Shaft	steel
Mechanical seal	SiC
Noise level	
SBA601	62 dBA
SBA602	66 dBA
SBA603...SBA604	71 dBA

