



NEW

TWIN VICES

from SMW-AUTOBLOK

FOR AUTOMATION

All products suitable for Industry 4.0 applications

SINTERGRIP JAWS

Lowest clamping depth without pre-marking

HIGH PRECISE

Highest repeatability

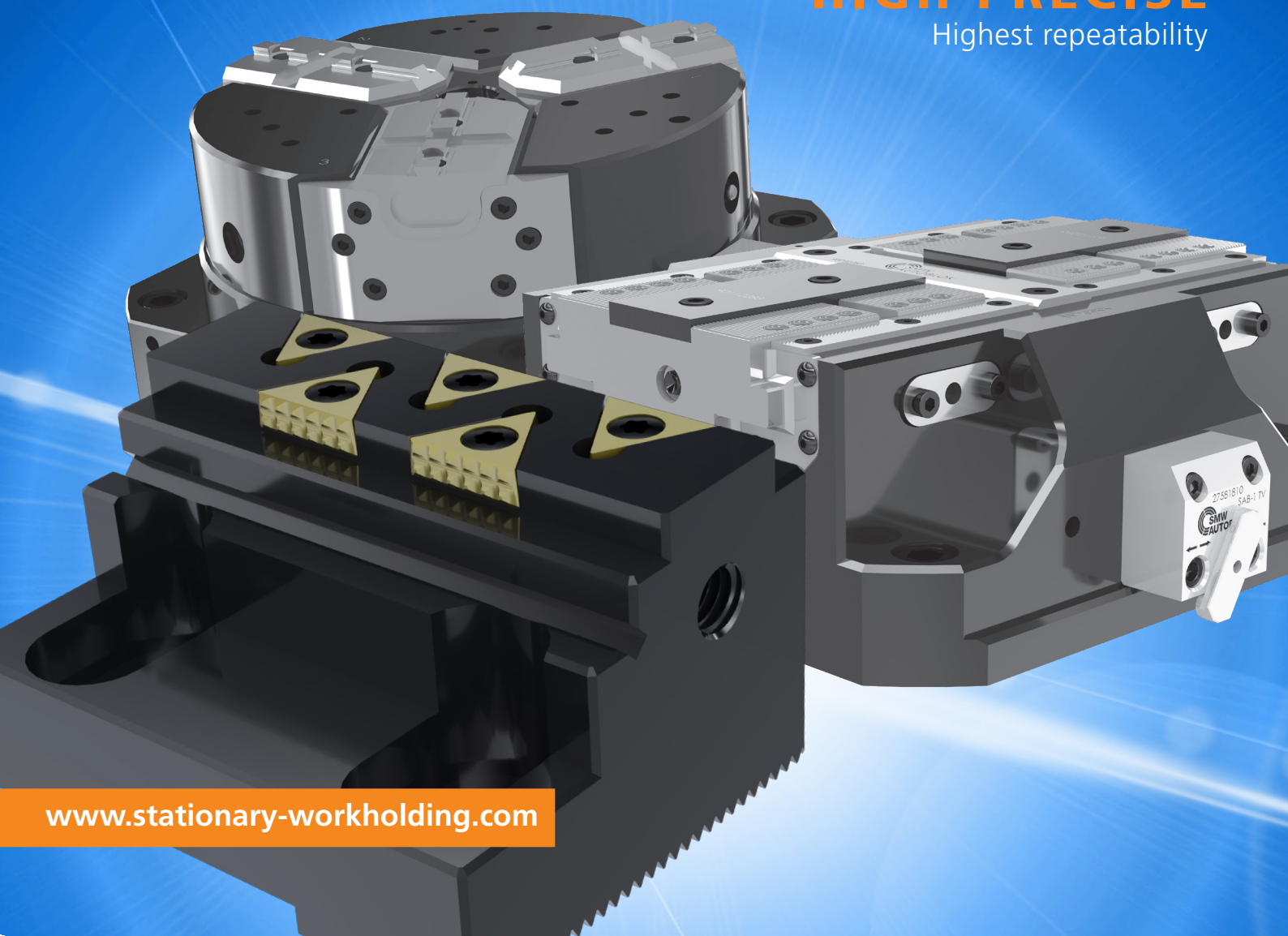

www.stationary-workholding.com



Twin Vices from SMW-AUTOBLOK

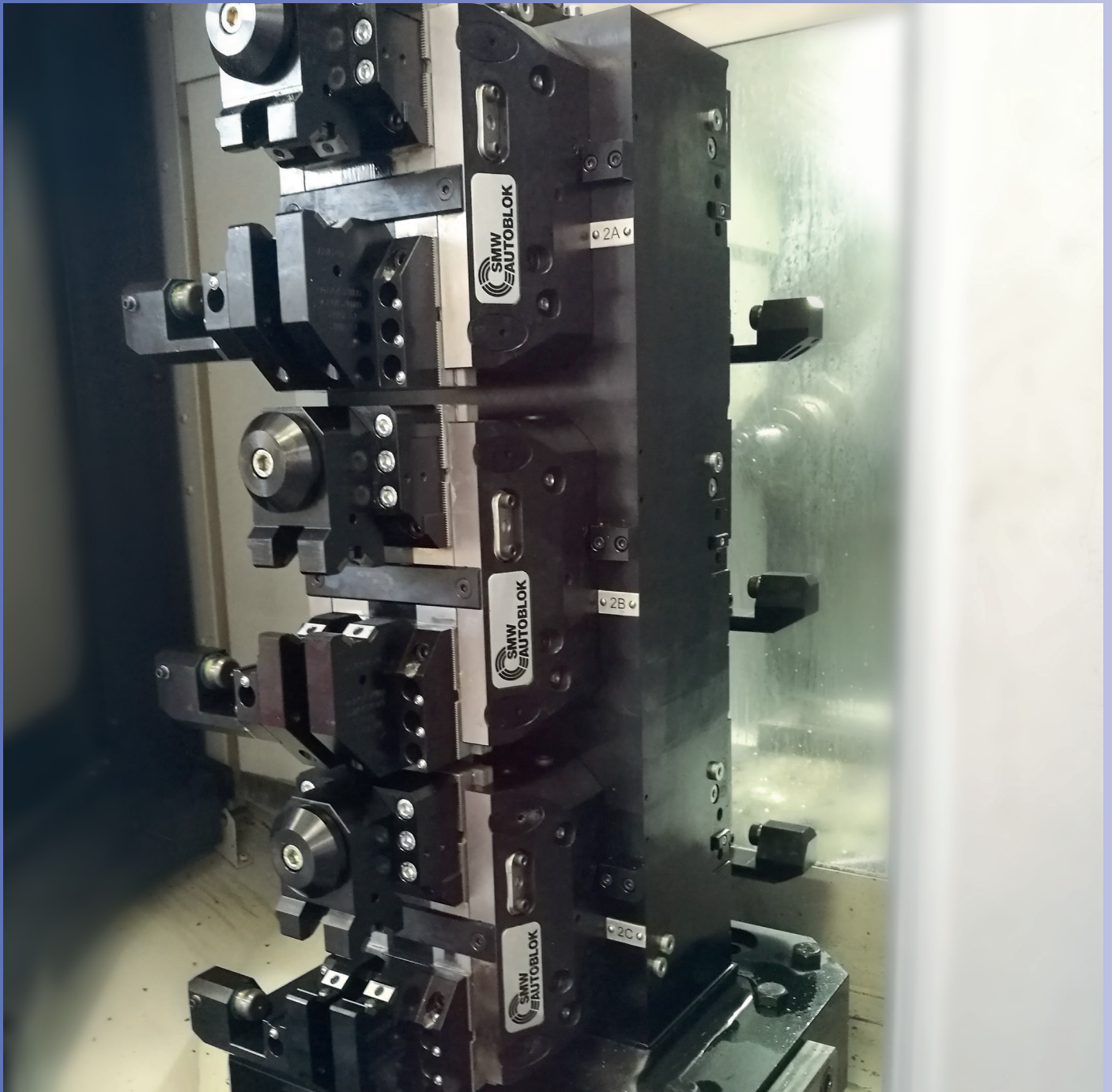

Twin Vices

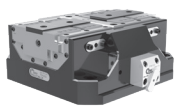

proofline® series
fully sealed – low maintenance

Page

6

STV-2

Spring and air operated vice 125, 180, 225

- Protected
- Springs to clamp, pneumatic to open
- Turbo function to increase the clamping forces
- Pneumatic jaw stroke control valve
- Normal stroke: STV-2N / Long stroke: STV-2L
- Air purge
- Air sensing



proofline® series
fully sealed – low maintenance

Page

18

PTP

Protected pneumatic vice 100, 125, 160, 200

- Protected against swarf and chips
- Pneumatic version
- Normal stroke: PTP-N / Long stroke: PTP-L
- Fixed jaw: PTP-F
- Pneumatic jaw stroke control valve
- Air purge
- Air sensing

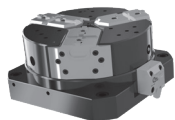

proofline® series
fully sealed – low maintenance

Page

8

STV-3

Spring and air operated vice 125, 180, 225

- Protected
- 3 jaws
- Springs to clamp, pneumatic to open
- Turbo function to increase the clamping forces
- Normal stroke: STV-3N
- Pneumatic jaw stroke control valve
- Air purge



proofline® series
fully sealed – low maintenance

Page

20

PTH

Protected hydraulic vice 100, 125, 160, 200

- Protected against swarf and chips
- Hydraulic version
- Normal stroke: PTH-N / Long stroke: PTH-L
- Pneumatic jaw stroke control valve
- Air purge
- Air sensing



Page

12

TVP

Pneumatic vice 100, 160, 200, 250, 315

- Normal stroke: TVP-N
- Long stroke: TVP-L
- Fixed jaw: TVP-F
- Air purge



proofline® series
fully sealed – low maintenance

Page

23

SL-P

Protected pneumatic vice 100, 160, 200

- Protected against swarf and chips
- Pneumatic version
- Normal stroke
- Air purge
- Air sensing



Page

14

TVH

Hydraulic vice 100, 160, 200

- Normal stroke: TVH-N
- Long stroke: TVH-L
- Air purge



Page

28

Jaws

Accessories

- Soft blank top jaw
- Tongue & Groove or fine serration 1.5 mm x 60°
- Jaws for SinterGrip

STV

Spring and Air operated

STV-2

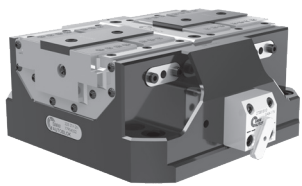

Function:

- Springs to clamp
- Turbo function to increase the clamping forces
- Pneumatic to open

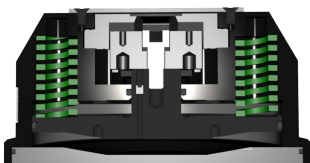

proofline® series
fully sealed – low maintenance

STV-3

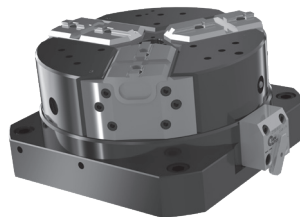

Function:

- Springs to clamp
- Turbo function to increase the clamping forces
- Pneumatic to open

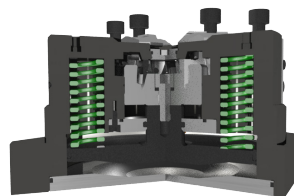

proofline® series
fully sealed – low maintenance

Proximities stroke control

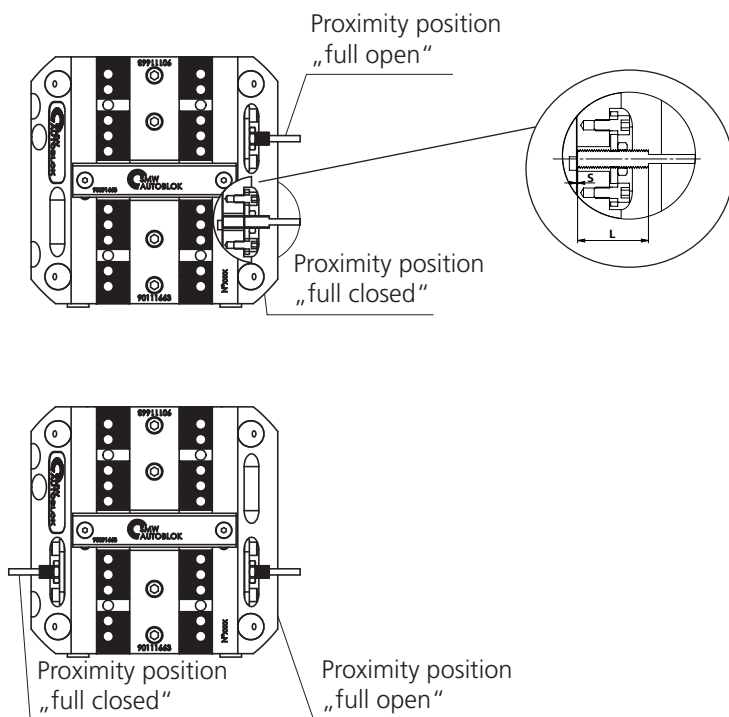

SinterGrip

For lowest clamping depth of workpieces and without pre-marking

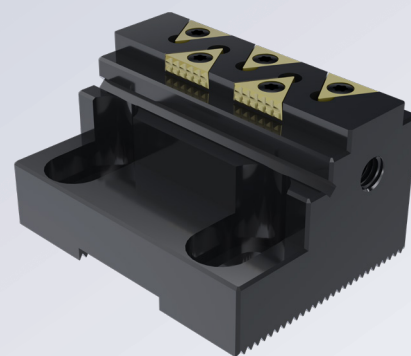

ed Power Vices



Convincing advantages

- Protected against contamination of swarf and chips, fully sealed (proofline)
- Compact design
- Highest repeatability
- Highest rigidity
- Housing and functional parts hardened for high precision and long life
- Air purge
- Master jaws with both tongue & groove and fine serration 1.5 mm x 60°
- OD clamping only
- Air sensing (only STV-2)
- Self-centering vice without top jaws
- All bolts and centering bushings included



Industry 4.0
Product



Safety valve SAB-1

- Safety valve SAB-1 to maintain air pressure during pallet transportation/storage and machining without feed
- Easy and smart opening of the vice by air gun
- Turbo function to increase the clamping forces

Pneumatic jaw stroke control valve (optional)

- For the monitoring of the jaw position
- Direct connection through the plate or the tombstone
- No cables needed
- Ideal for automation

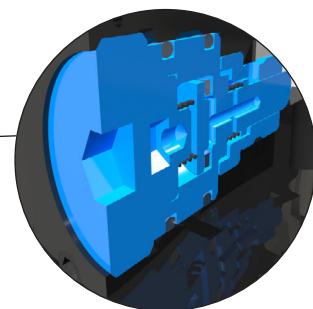
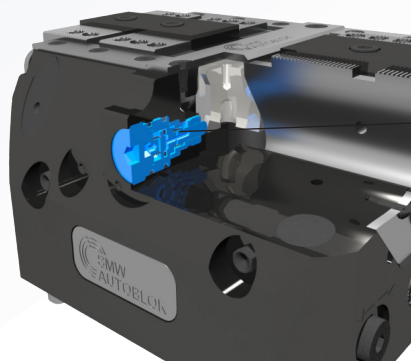

STV-2N

STV-2L

Spring and air operated twin vice

NORMAL STROKE

LONG STROKE

- Protected
- Springs clamping
- Pneumatic jaw stroke control valve

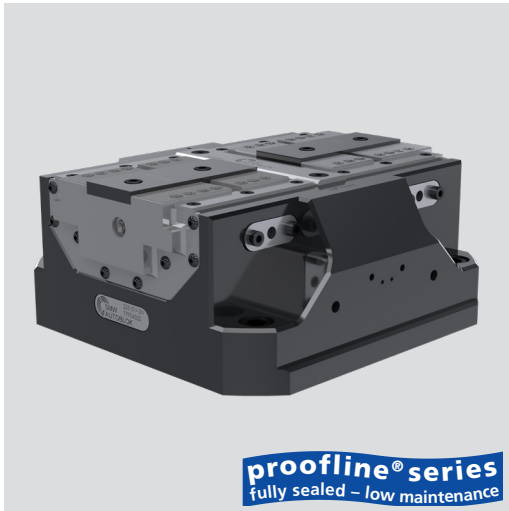

Application/customer benefits

- Protected against contamination of swarf and chips, fully sealed (proofline)
- Compact design
- Highest repeatability
- Highest rigidity

Technical features

- Spring to clamp, pneumatic open
- Increase of the clamping force via Turbo function
- Housing and functional parts hardened for high precision and long life
- Air purge
- Master jaws with both Tongue & Groove and fine serration 1.5 mm x 60°
- OD clamping only
- Safety valve SAB-1 to maintain air pressure during pallet transportation/storage and machining without feed (optional)
- Pneumatic jaw stroke control valve (optional)
- Stroke control via proximity switches (optional)
- Air sensing

Standard equipment

Self-centering vice without top jaws
All bolts and centering bushings included

Actual gripping force diagrams

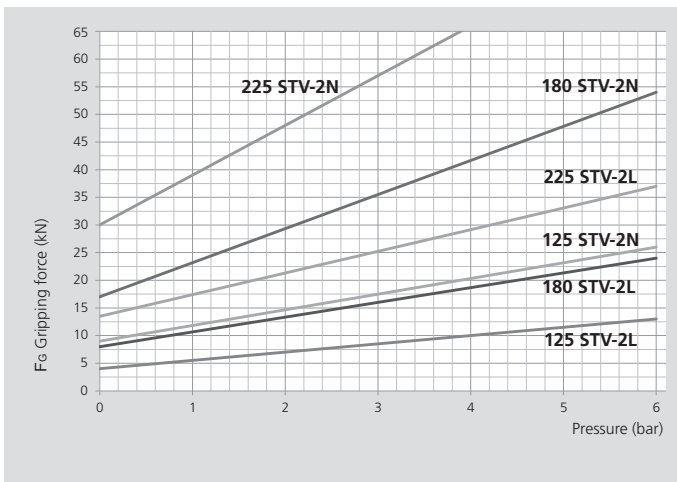

SAB-1 safety valve

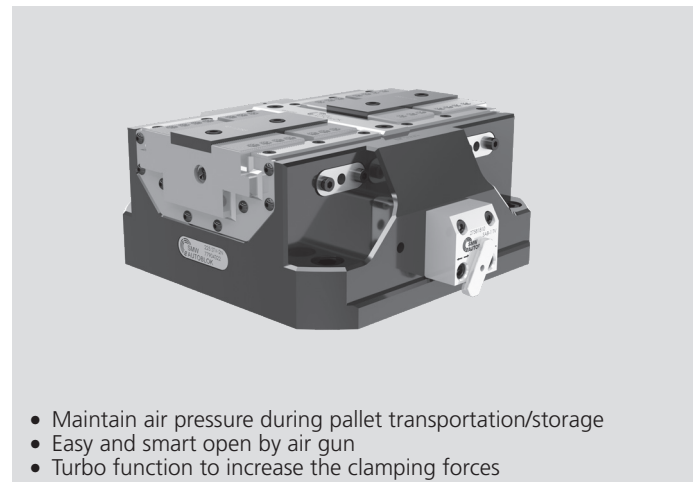

Technical data

Type	Id. No.	Id. No. incl. SAB-1 valve	Type Stroke	Max. clamping force middle stroke		Stroke/ Jaw mm	Piston area cm ²	Re- opening pressure bar	Ope- rating pressure bar	Repeatabi- lity mm	Weight kg
				Springs kN	Springs+Turbo kN						
125 STV-2N	77904312	77904812	Normal	9	26	2.6	78	5	6	0.01	7
125 STV-2L	77904412	77904818	Long	4	13	6	78	5	6	0.01	7
180 STV-2N	77904318	77904822	Normal	17	54	3	170	5	6	0.01	17.5
180 STV-2L	77904418	77904912	Long	8	24	8.4	170	5	6	0.01	17.5
225 STV-2N	77904322	77904918	Normal	30	66	4.2	250	6	4	0.02	28
225 STV-2L	77904422	77904922	Long	13.5	37	10.2	250	6	6	0.02	28

Spring and air operated twin vice

STV-2N

STV-2L

- Protected
- Springs clamping
- Pneumatic jaw stroke control valve

NORMAL STROKE

LONG STROKE

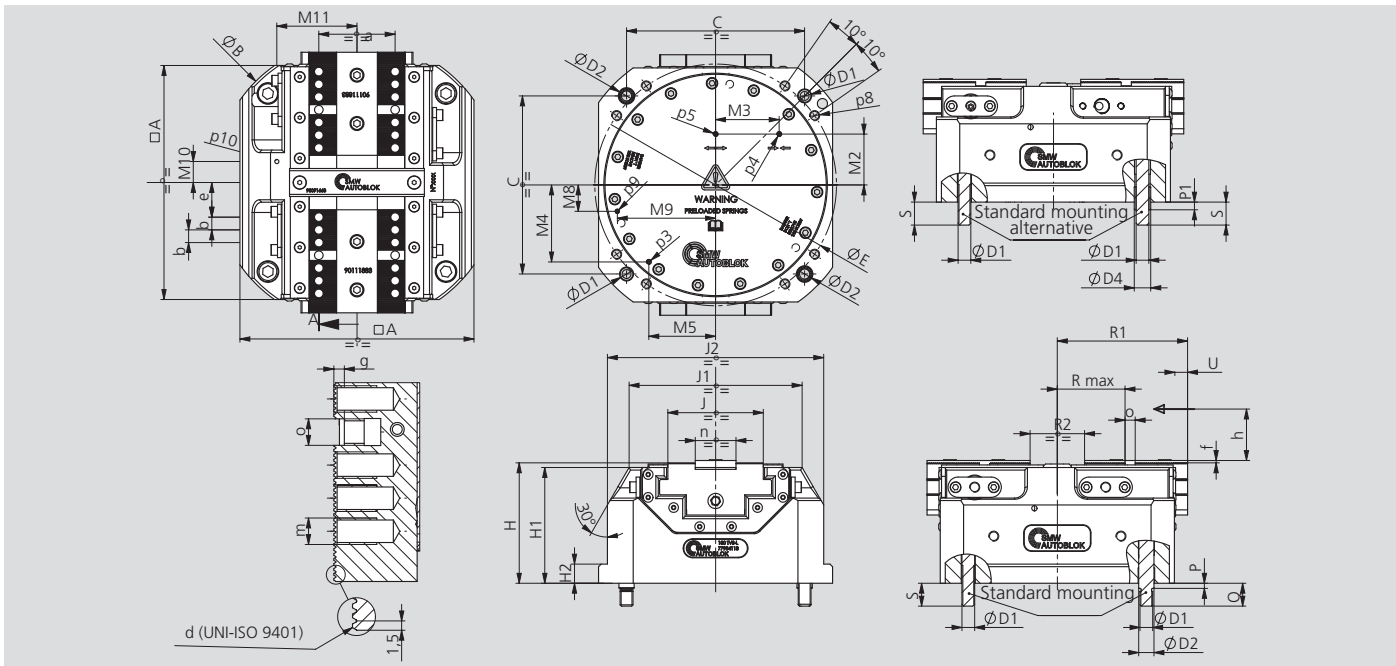

SMW-AUTOBLOK Type			STV-2 125	STV-2 180	STV-2 225
	A	mm	125	184	225
	B(∅)	mm	162	225	284
	C	mm	100	140	180
	D1(∅)	mm	M8	M10	M12
	D2 (∅f7)	mm	10	12	14
	D4 (∅js7)	mm	11	13	16
	E (∅)	mm	136	190	240
	H	mm	80.5	94.7	102
	H1	mm	77	91	98
	H2	mm		15	15
	J	mm	47	75	94
	J1	mm	100	136	172
	J2	mm	125	170	216
	M2	mm	32	40	50
	M3	mm	29.5	50	65
	M4	mm	40.5	60.5	79
	M5	mm	38.5	52.5	63
	P	mm	4	4	5
	P1	mm	4	6	6
	Q	mm	15	18	20
min/max (long stroke)	R max	mm	25.6/31.6	44.8/53.2	54.5/64.7
min/max (normal stroke)	R max	mm	25.4/28	45/48	54.5/58.7
min/max (long stroke)	R1	mm	64.5/70.5	94/102.4	114.5/124.7
min/max (normal stroke)	R1	mm	64.4/67	94.5/97.5	114.8/119
min/max (long stroke)	R2	mm	20/32	26/42.8	30/50.4
min/max (normal stroke)	R2	mm	19.8/25	26/32	30.6/39
	S	mm	15	18	20
long stroke	U	mm	6	8.4	10.2
normal stroke	U	mm	2.6	3	4.2
	a	mm	35	60	80
	b	mm	7	10	10
serration	d	mm	1.5x60°	1.5x60°	1.5x60°
min/max (long stroke)	e	mm	14.6/20.6	18.8/27.2	28.5/38.7
min/max (normal stroke)	e	mm	14.4/17	19/22	28.5/32.7
	f	mm	1.8	1.8	2
	g	mm	2.7	3.2	4
	h	mm	16	25	35
	m	mm	M6x10	M8x12	M8x12
	n (g6)	mm	20	32	40
	o (H7)	mm	6	8	8
	p3	mm	M4	M4	M4
	p4	mm	M4	M4	M4
	p5	mm	M4	M4	M4
	p8	mm	M6x12	M8x16	M10x18
	p9	mm	M4	M4	M4
	p10	mm	M4	M4	M4
	M8	mm	10.6	20.7	15
	M9	mm	54.5	77.3	99.9
	M10	mm	10.5	16.5	15
	M11	mm	46	63	81

STV-3N

NORMAL STROKE

Spring and air operated twin vice

- Protected
- 3 jaws
- Springs clamping
- Pneumatic jaw stroke control valve



proofline® series
fully sealed – low maintenance

Application/customer benefits

- Protected against contamination of swarf and chips, fully sealed (proofline)
- Compact design
- Highest repeatability
- Highest rigidity

Technical features

- Spring to clamp, pneumatic open
- Increase of the clamping force via Turbo function
- Housing and functional parts hardened for high precision and long life
- Air purge
- Master jaws with both Tongue & Groove
- OD clamping only
- Safety valve SAB-1 to maintain air pressure during pallet transportation/storage and machining without feed
- Pneumatic jaw stroke control valve (optional)

Standard equipment

Self-centering vice without top jaws
All bolts and centering bushings included

Actual gripping force diagrams

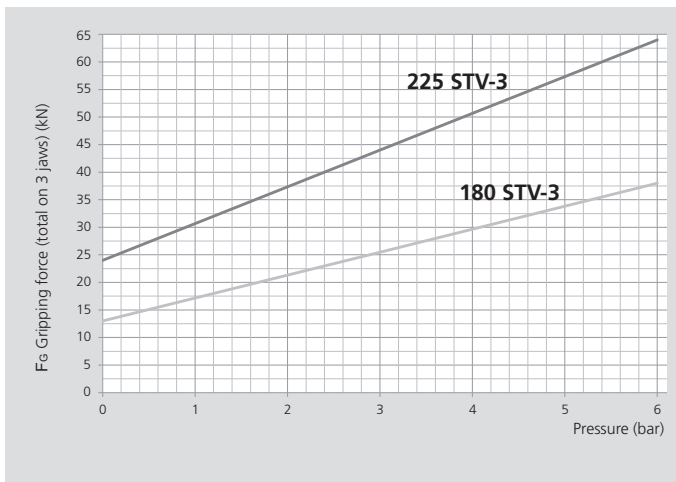

SAB-1 safety valve

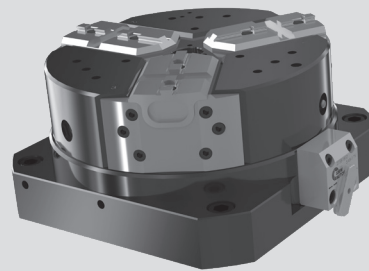

- Maintain air pressure during pallet transportation/storage
- Easy and smart open by air gun
- Turbo function to increase the clamping forces

Technical data

Type	Id. No.	Id. No. incl. SAB-1 valve	Type Stroke	Max. clamping force middle stroke		Stroke/ Jaw mm	Piston area cm ²	Re- opening pressure bar	Ope- rating pressure bar	Weight kg
				Springs kN	Springs+Turbo kN					
125 STV-3	on request	on request	Normal							
180 STV-3	77904618	77905018	Normal	13	38	3.8	170	5	6	18
225 STV-3	77904622	77905022	Normal	24	64	4.2	250	6	6	29.5

Spring and air operated twin vice

- Protected
- 3 jaws
- Springs clamping
- Pneumatic jaw stroke control valve

STV-3N

NORMAL STROKE

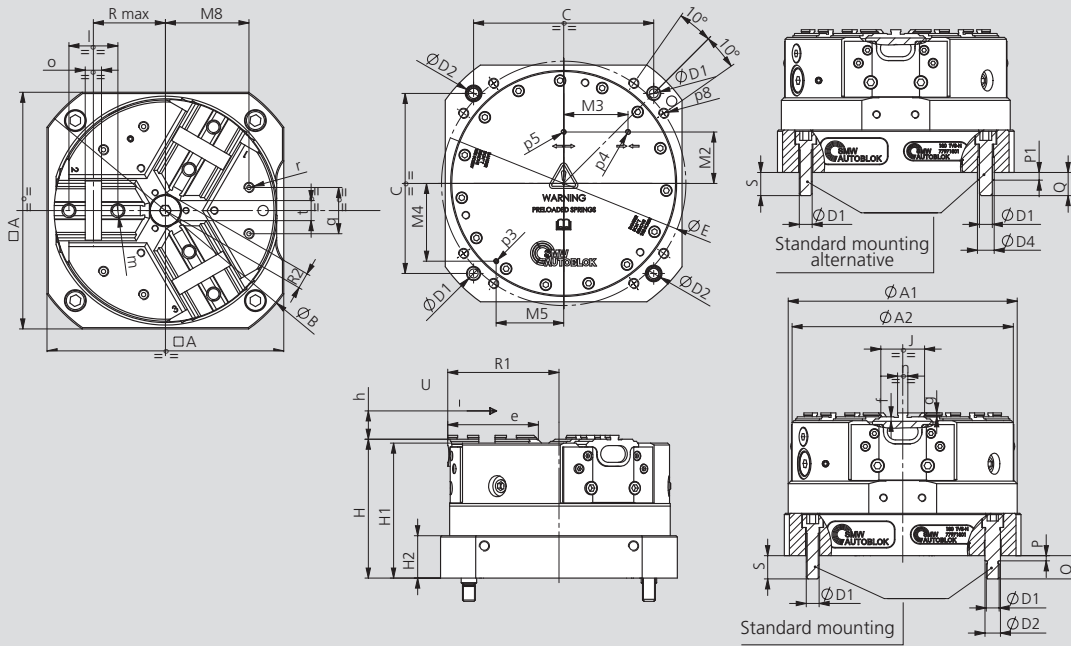

SMW-AUTOBLOK Type			STV-3 180	STV-3 225
	A	mm	184	225
	A1	mm	178	222
	A2	mm	172	216
	B(Ø)	mm	225	284
	C	mm	140	180
	D1(Ø)	mm	M10	M12
	D2 (Øf7)	mm	12	14
	D4 (Øjs7)	mm	13	16
	E (ø)	mm	190	240
	H	mm	108	115
	H1	mm	105	112
	H2	mm	33	38
	J	mm	34	46
	M2	mm	40	50
	M3	mm	50	65
	M4	mm	60.5	79
	M5	mm	52.5	63
	M8	mm	65	80
	P	mm	4	5
	P1	mm	6	6
	Q	mm	18	20
min/max	R max	mm	52.2/56	67.8/72
min/max	R1	mm	82.7/86.5	103.8/108
min/max	R2	mm	8.7/12.5	12.8/17
	S	mm	18	20
	U	mm	3.8	4.2
	e	mm	70	87
	f	mm	3.5	3.5
	g	mm	3	3
	h	mm	25	35
	l	mm	38	44.4
	m	mm	M10x12	M12x14
	n (h8)	mm	7.94	7.94
	o (H7)	mm	12.68	12.68
Air stroke control or Air purge	p3	mm	M4	M4
Vice Closed	p4	mm	M4	M4
Vice Open	p5	mm	M4	M4
	p8	mm	M8x16	M10x18
	q	mm	36	45
	r	mm	M8x10	M8x10
min/max	t	mm	9/15.6	13.5/20.9

■ Mounting instruction

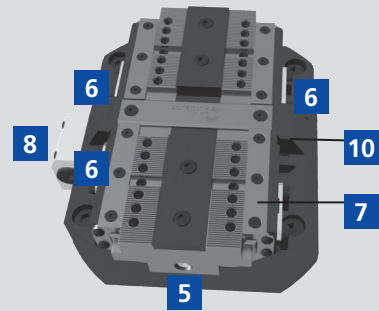
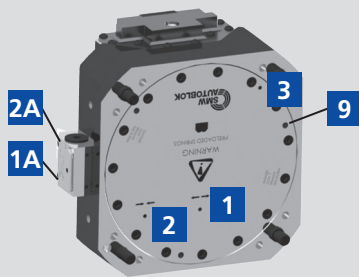

Solution 1 Standard

± 0,03 mm to clamping center

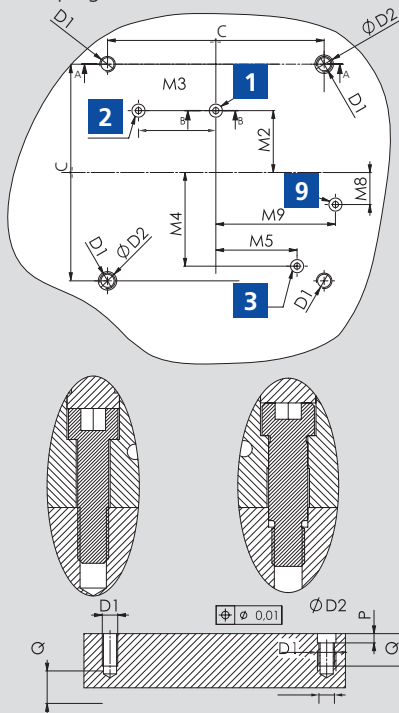

All bolts and centering bushings included

Solution 2 Standard

± 0,025 mm to clamping center

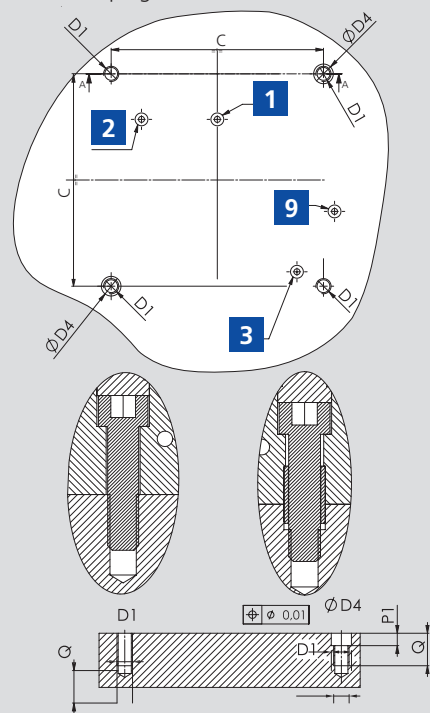

All bolts and centering bushings included

Feeding seats

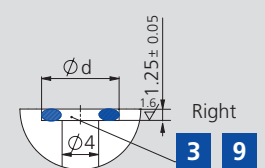
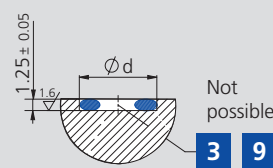
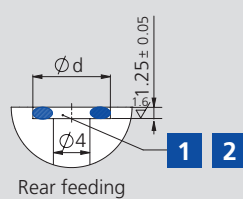
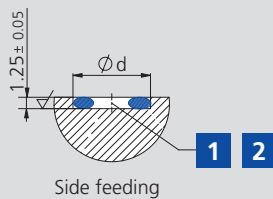

Functional Overview

1 Open-Rear feeding	1A Open-Side feeding	6 Proximity switches seats	9 Air sensing connection**
2 Closed-Rear feeding	2A Closed-Side Feeding	7 Pneumatic stroke control valve	10 Air sensing outlet** (under front plate)
3 Pneumatic stroke control or air purge*	5 Lubrication fitting	8 Safety valve	

* The air purge can be used only without the valve.

**9 and 10 Points available only on 2 jaws version.

Type	C	D1	D2 H7	D4 H7	M2	M3	M4	M5	M8	M9	P	P1	Q	Ød	OR
STV 125	100	M8	10	11	32	29.5	40.5	38.5	10.6	54.5	6	6	18	8	OR2018
STV 180	140	M10	12	13	40	50	60.5	52.5	20.7	77.3	6	7	21	8.8	OR2021
STV 225	180	M12	14	16	50	65	79	63	15	99.9	7	7	24	8.8	OR2021

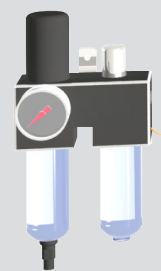
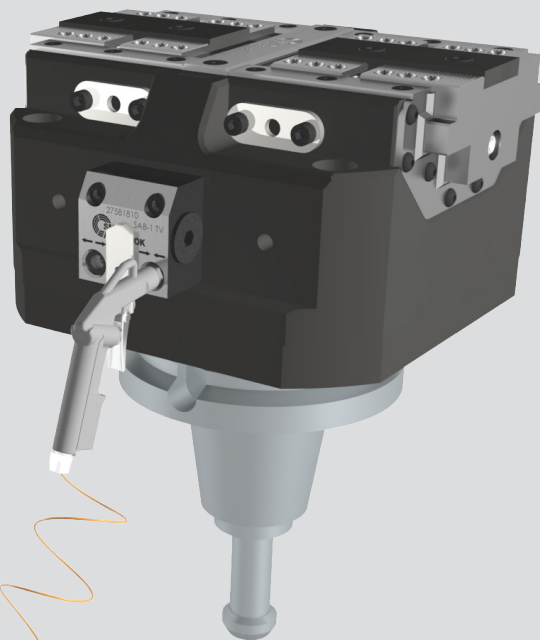
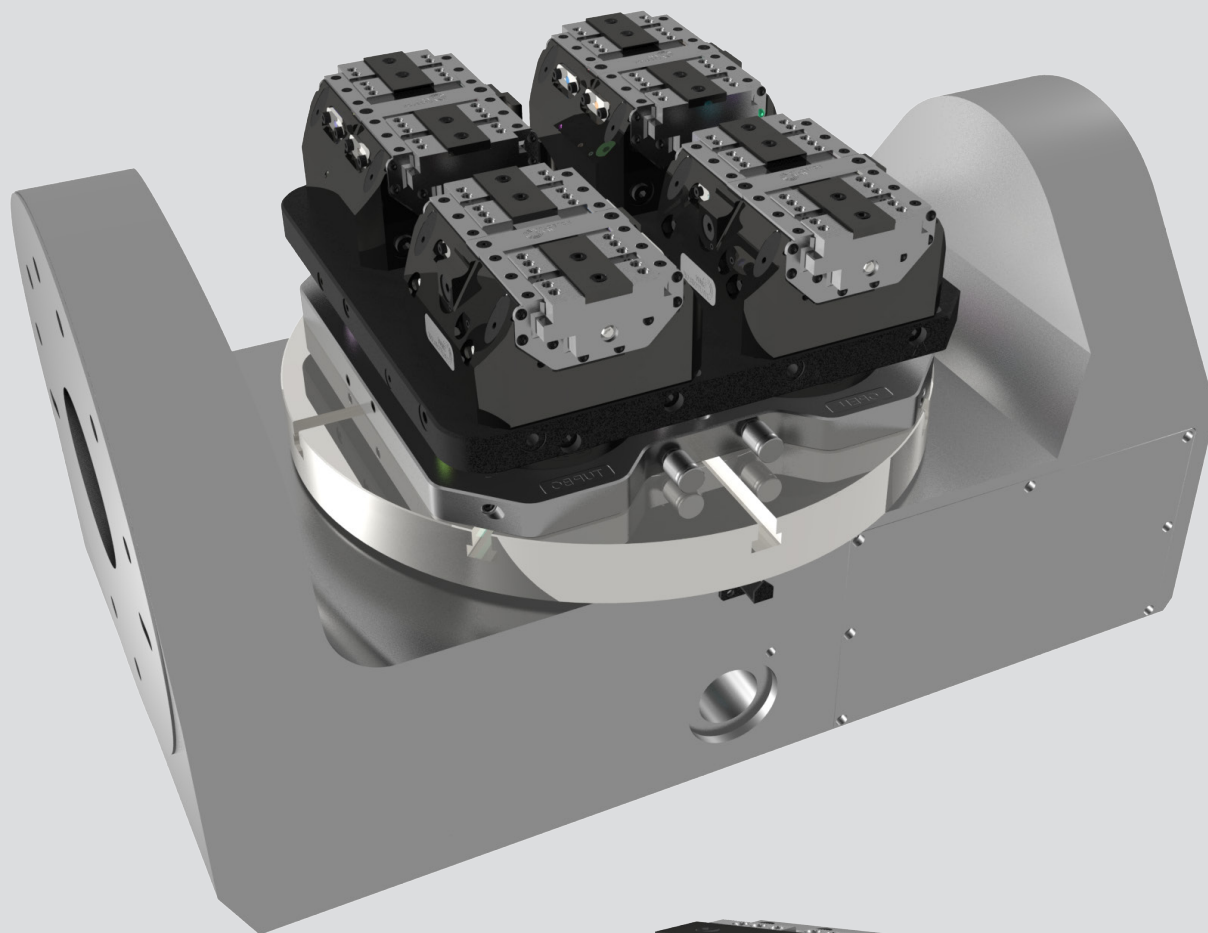

TVP-N**TVP-L****TVP-F****Pneumatic twin vice**

NORMAL STROKE

LONG STROKE

FIXED JAW

**Application/customer benefits**

- Compact design
- Linear pressure adjustment
- Highest repeatability
- Highest rigidity

Technical features

- H7 quality pilot bore
- Housing and functional parts hardened for high precision and long life
- Air purge
- Ready for central grease lubrication
- Master jaws with both Tongue & Groove and fine serration 1.5 mm x 60°
- OD and ID clamping
- Stroke control via proximity switches (optional)

Standard equipment

Self-centering vice without top jaws
All bolts and centering bushings included

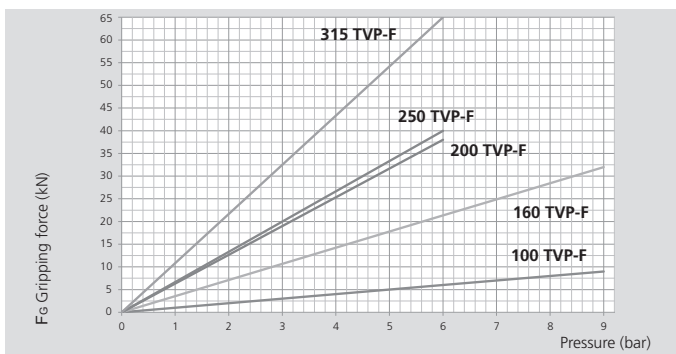
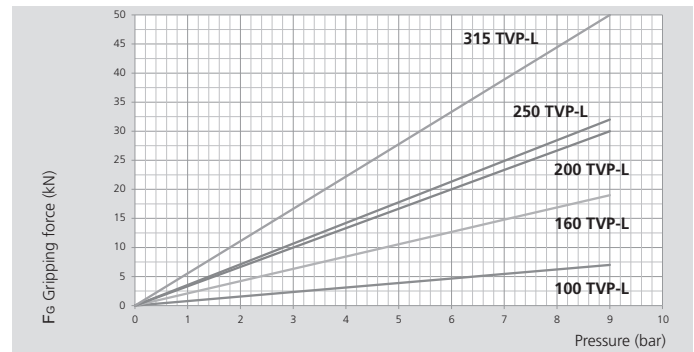
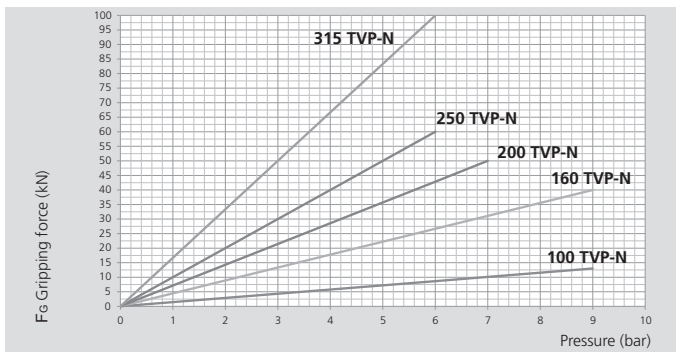
Actual gripping force diagrams**Technical data**

Type	Id. No.	Stroke Type	Max. clamping force kN	Stroke / Jaw mm	Max. operating pressure bar	Repeatability mm	Weight kg
100 TVP-N	77903010	Normal	13	2.6	9	0.01	4.3
100 TVP-L	77903110	Long	7	6	9	0.01	4.3
100 TVP-F	77903210	Fixed jaw	9	6	9	0.01	4.3
160 TVP-N	77903016	Normal	40	3	9	0.01	13
160 TVP-L	77903116	Long	19	8.4	9	0.01	13
160 TVP-F	77903216	Fixed jaw	32	8.4	9	0.01	13
200 TVP-N	77903020	Normal	50	4.2	7	0.02	23
200 TVP-L	77903120	Long	30	10.2	9	0.02	23
200 TVP-F	77903220	Fixed jaw	38	10.2	6	0.02	23
250 TVP-N	77903025	Normal	60	5.3	6	0.02	39
250 TVP-L	77903125	Long	32	15	9	0.02	39
250 TVP-F	77903225	Fixed jaw	40	15	6	0.02	39
315 TVP-N	77903031	Normal	100	6.4	6	0.03	84
315 TVP-L	77903131	Long	50	18	9	0.03	84
315 TVP-F	77903231	Fixed jaw	65	18	6	0.03	84

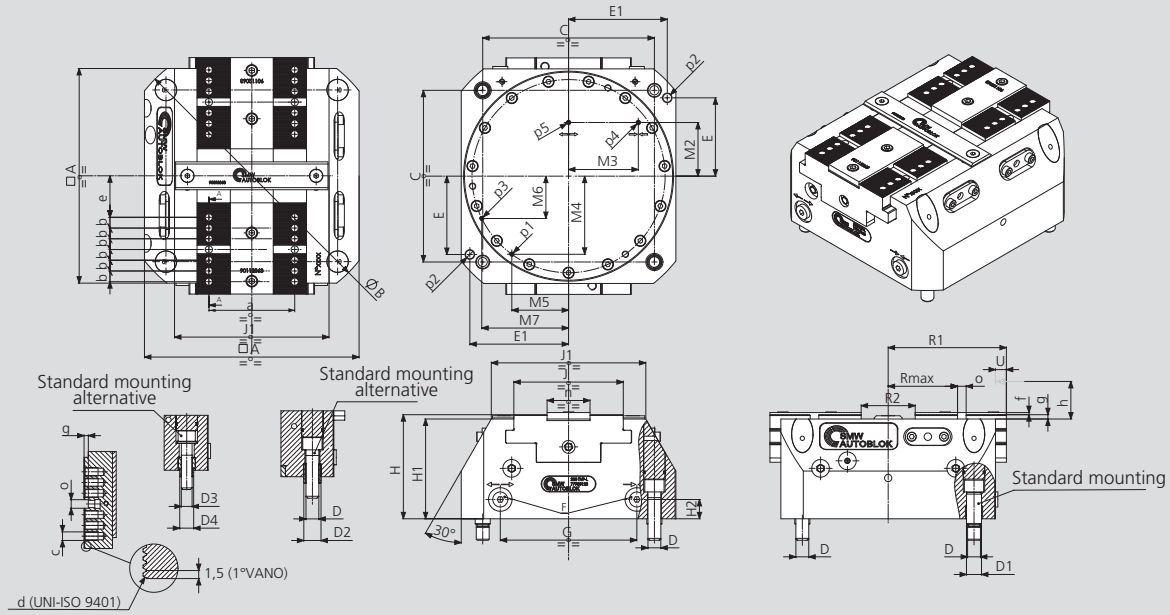

SMW-AUTOBLOK Type		TVP-N TVP-L TVP-F 100	TVP-N TVP-L TVP-F 160	TVP-N TVP-L TVP-F 200	TVP-N TVP-L TVP-F 250	TVP-N TVP-L TVP-F 315	
A	mm	100	160	200	250	315	
B(Ø)	mm	132	205	255	314	394	
C	mm	80	125	160	200	250	
D(Ø)	mm	M8x15	M10x18	M12x20	M12x20	M16x23	
D1 (Øf7)	mm	10x4	12x4	14x5	14x5	18x6	
D2 (Øjs7)	mm	11x4	13x6	16x6	16x6	21x6	
D3	mm	-	-	M10x18	-	-	
D4 (Øjs7)	mm	-	-	13x6	-	-	
E	mm	32	53	73	77	105	
E1	mm	45	73	92	115	140	
F	mm	M5	G1/8"	G1/8"	G1/8"	G1/8"	
G	mm	59.3	99	127.3	157	200.8	
H	mm	75.5	89.7	97	105	139	
H1	mm	72	86	93	100	133	
H2	mm	15	18	18	20	25	
J	mm	47	75	102	125	160	
J1	mm	72	108	144	180	230	
M2	mm	32	40	50	64	80	
M3	mm	29.5	50	65	75	90	
M4	mm	34.2	59	72.8	89.8	117.7	
M5	mm	27.7	41	52.9	65.2	79.4	
M6	mm	14.2	30.7	39.5	48.7	57.8	
M7	mm	41.1	62.9	80.9	99.8	129.7	
Lubrication	p1	mm	M4	M4	M5	M5	
	p2 ØH7	mm	6x14	8x14	8x14	10x20	12x20
Air purge	p3	mm	M4	M4	M4	M5	M5
Vice closed	p4	mm	M4	M4	M4	M5	M5
Vice open	p5	mm	M4	M4	M4	M5	M5
min/max (long stroke)	R2	mm	20/32	26/42.8	30/50.4	39/69	50/86
min/max (long stroke)	R1	mm	50/56	82.5/90.9	100/110.2	119.5/134.5	151.5/169.5
min/max (long stroke)	Rmax	mm	25.6/31.6	44.8/53.2	54.5/64.7	51.5/66.5	81.5/99.5
min/max (normal stroke)	R2	mm	19.8/25	26/32	30.6/39	34.4/45	49.2/62
min/max (normal stroke)	R1	mm	47.4/50	82.5/85.5	95.8/100	119.7/125	151.1/157.5
min/max (normal stroke)	Rmax	mm	25.4/28	45/48	54.5/58.7	55.7/61	87.1/93.5
min/max (fixed jaw)	R2	mm	20/26	26/34.4	30/40.2	39/54	56/74
min/max (fixed jaw)	R1	mm	50/56	82.5/90.9	100/110.2	119.5/134.5	151.5/169.5
min/max (fixed jaw)	Rmax	mm	25.6/31.6	44.8/53.2	54.5/64.7	51.5/66.5	81.5/99.5
Long stroke	U	mm	6	8.4	10.2	15	18
Normal stroke	U	mm	2.6	3	4.2	5.3	6.4
Fixed jaw stroke	U	mm	6	8.4	10.2	15	18
a	mm	35	60	80	90	120	
b	mm	7	10	10	12	15	
c	mm	M6x10	M8x12	M8x12	M10x15	M12x17	
Serration	d	mm	1.5x60°	1.5x60°	1.5x60°	1.5x60°	1.5x60°
min/max (normal stroke)	e	mm	14.4/17	19/22	28.5/32.7	24.7/30	33.1/39.5
min/max (long stroke)	e	mm	14.6/20.6	18.8/27.2	28.5/38.7	32.5/47.5	42.5/60.5
min/max (fixed jaw)	e	mm	14.6/20.6	18.8/27.2	28.5/38.7	32.5/47.5	42.5/60.5
f	mm	1.8	1.8	2	2.5	2.5	
g	mm	2.7	3.2	4	4	4	
h	mm	16	25	35	40	40	
o (H7)	mm	6	8	8	10	12	
n (g6)	mm	20	32	40	50	60	

TVH-N**TVH-L****Hydraulic twin vice**

NORMAL STROKE

LONG STROKE

**Application/customer benefits**

- Compact design
- Linear pressure adjustment
- Highest repeatability
- Highest rigidity

Technical features

- H7 quality pilot bore
- Housing and functional parts hardened for high precision and long life
- Air purge
- Ready for central grease lubrication
- Master jaws with both Tongue & Groove and fine serration 1.5 mm x 60°
- OD and ID clamping
- Stroke control via proximity switches (optional)

Standard equipment

Self-centering vice without top jaws
All bolts and centering bushings included

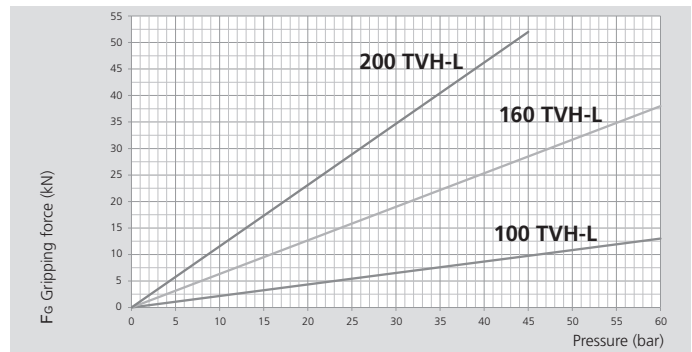
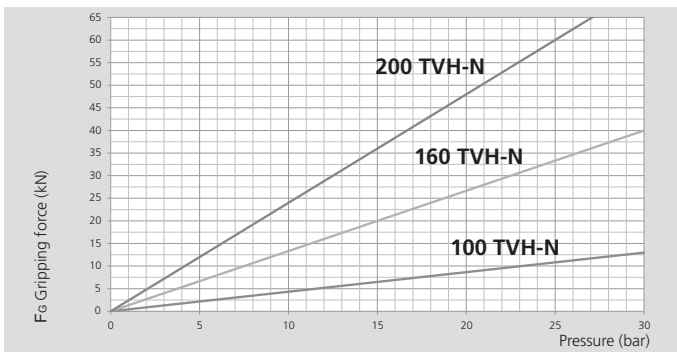
Actual gripping force diagrams**Technical data**

Type	Id. No.	Stroke Type	Max. clamping force kN	Stroke / Jaw mm	Max. operating pressure bar	Repeatability mm	Weight kg
100 TVH-N	77903510	Normal	13	2.6	30	0.01	4.5
100 TVH-L	77903610	Long	13	6	60	0.01	4.5
160 TVH-N	77903516	Normal	40	3	30	0.01	14
160 TVH-L	77903616	Long	38	8.4	60	0.01	14
200 TVH-N	77903520	Normal	60	4.2	25	0.02	25
200 TVH-L	77903620	Long	52	10.2	45	0.02	25

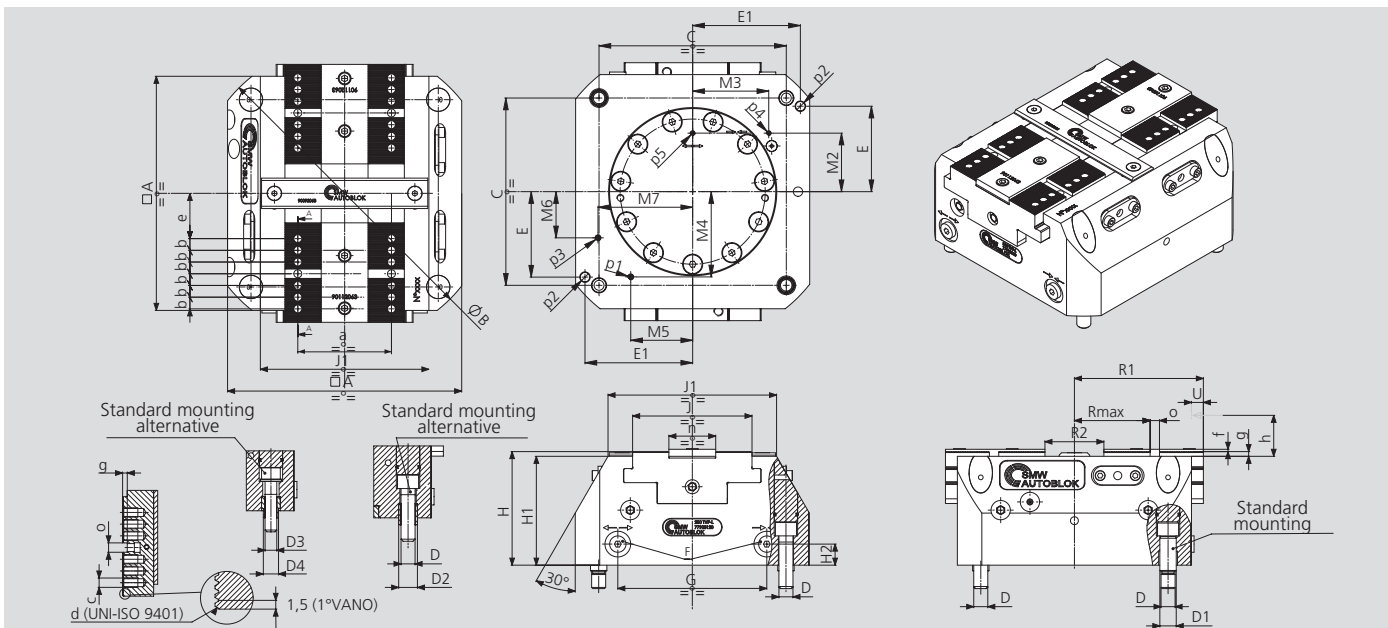

SMW-AUTOBLOK Type		TVH-N TVH-L 100	TVH-N TVH-L 160	TVH-N TVH-L 200	
	A	mm	100	160	200
	B(Ø)	mm	132	205	255
	C	mm	80	125	160
	D(Ø)	mm	M8x15	M10x18	M12x20
	D1 (Øf7)	mm	10x4	12x4	14x5
	D2 (Øjs7)	mm	11x4	13x6	16x6
	D3	mm	-	-	M10x18
	D4 (Øjs7)	mm	-	-	13x6
	E	mm	32	53	73
	E1	mm	45	73	92
	F	mm	G1/8"	G1/8"	G1/8"
	G	mm	55	98	128
	H	mm	75.5	89.7	97
	H1	mm	72	86	93
	H2	mm	15	18	18
	J	mm	47	75	102
	J1	mm	72	108	144
	M2	mm	32	40	50
	M3	mm	29.5	50	65
	M4	mm	34.2	59	72.8
	M5	mm	27.7	41	52.9
	M6	mm	14.2	30.7	39.5
	M7	mm	41.1	62.9	80.9
Lubrication	p1	mm	M4	M5	M5
	p2 ØH7	mm	6x14	8x14	8x14
Air purge	p3	mm	M4	M5	M5
Vice closed	p4	mm	M4	M4	M4
Vice open	p5	mm	M4	M4	M4
min/max (long stroke)	R2	mm	20/32	26/42.8	30/50.4
min/max (long stroke)	R1	mm	50/56	82.5/90.9	100/110.2
min/max (long stroke)	Rmax	mm	25.6/31.6	44.8/53.2	54.5/64.7
min/max (normal stroke)	R2	mm	19.8/25	26/32	30.6/39
min/max (normal stroke)	R1	mm	47.4/50	82.5/85.5	95.8/100
min/max (normal stroke)	Rmax	mm	25.4/28	45/48	54.5/58.7
Long stroke	U	mm	6	8.4	10.2
Normal stroke	U	mm	2.6	3	4.2
	a	mm	35	60	80
	b	mm	7	10	10
	c	mm	M6x10	M8x12	M8x12
Serration	d	mm	1.5x60°	1.5x60°	1.5x60°
min/max (normal stroke)	e	mm	14.4/17	19/22	28.5/32.7
min/max (long stroke)	e	mm	14.6/20.6	18.8/27.2	28.5/38.7
	f	mm	1.8	1.8	2
	g	mm	2.7	3.2	4
	h	mm	16	25	35
	o (H7)	mm	6	8	8
	n (g6)	mm	20	32	40

■ Mounting instruction

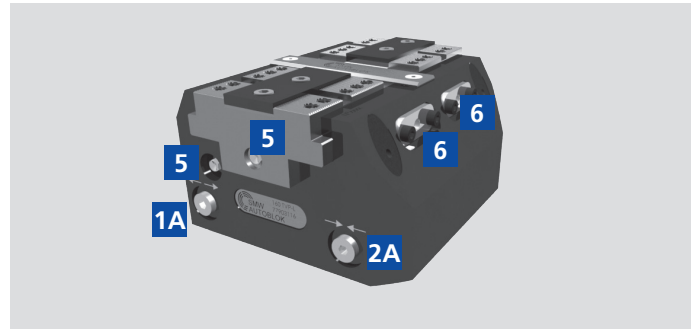
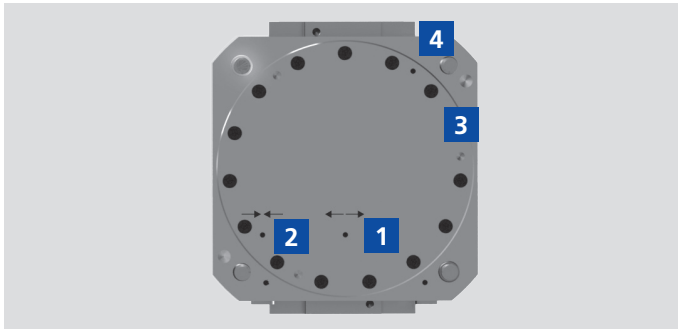

Solution 1 Standard

± 0,03 mm to clamping center

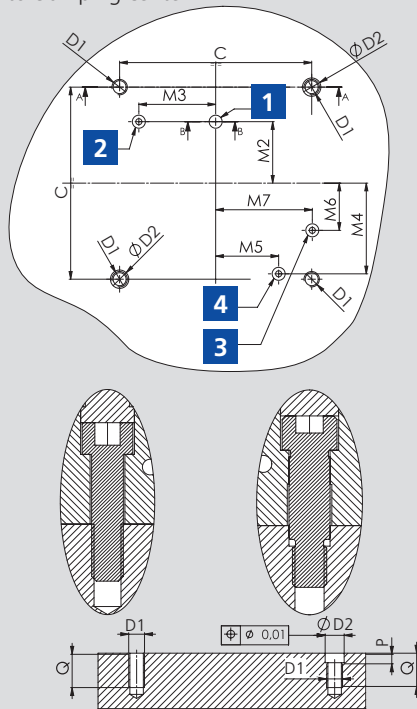

All bolts and centering bushings included

Solution 2 Standard

± 0,025 mm to clamping center

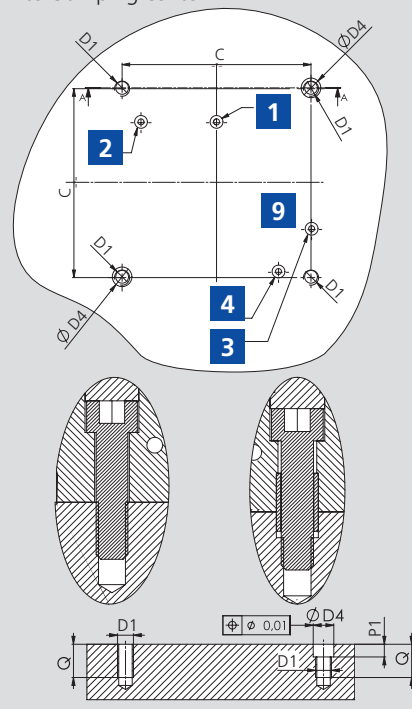

All bolts and centering bushings included

Feeding seats

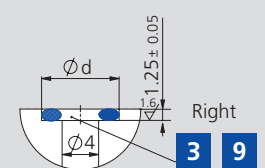
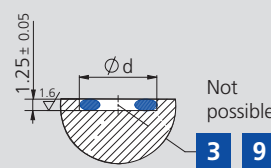
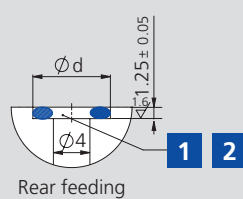
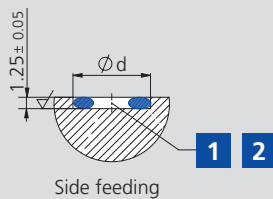

Functional Overview

- 1** Open-Rear feeding
- 2** Closed-Rear feeding
- 3** Air purge
- 5** Lubrication fitting
- 1A** Open-Side feeding
- 2A** Closed-Side Feeding
- 4** Central lubrication
- 6** Proximity switches seats

Type	C	D1	D2H7	D4H7	M	M1	M2	M3	M4	M5	M6	M7	P	P1	Q	V	Z	Ød	OR
TV 100	80	M8	10	11	45	29	32	29.5	34.2	27.7	14.2	41.1	6	6	18	37.3	96.5	8	OR2018
TV 160	125	M10	12	13	69	48	40	50	59	41	30.7	62.9	6	7	21	50	155	8	OR2018
TV 200	160	M12	14	16	88	62	50	65	72.8	52.9	39.5	80.9	7	7	24	62	195	8.8	OR2021
TV 250	200	M12	14	16	113	77	64	75	89.8	65.2	48.6	99.8	7	7	24	80	239	8.8	OR2021
TV 315	250	M15	18	21	-	-	80	90	115.7	84	62.7	128.5	8	7	27	-	-	8.8	OR2021

Notes

A large area of horizontal stripes in two shades of blue, alternating between a medium blue and a light blue. This area is intended for writing notes.

PTP-N**PTP-L****PTP-F****Protected pneumatic twin vice**

NORMAL STROKE

LONG STROKE

FIXED JAW

- Pneumatic version
- Pneumatic jaw stroke control valve

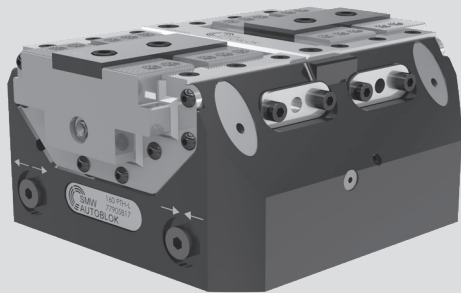

proofline® series
fully sealed – low maintenance

Application/customer benefits

- Protected against contamination of swarf and chips, fully sealed (proofline)
- Compact design
- Highest repeatability
- Highest rigidity
- Linear pressure adjustment

Technical features

- Housing and functional parts hardened for high precision and long life
- Air purge
- Ready for central grease lubrication
- Master jaws with both Tongue & Groove and fine serration 1.5 mm x 60°
- OD and ID clamping
- Pneumatic jaw stroke control valve (optional)
- Air sensing
- Stroke control via proximity switches on all types and sizes except 100 PTP-F (optional)
- For 100 PTP-F only one stroke control via proximity switch for vice closed (optional)

Standard equipment

Self-centering vice without top jaws
All bolts and centering bushings included

Actual gripping force diagrams

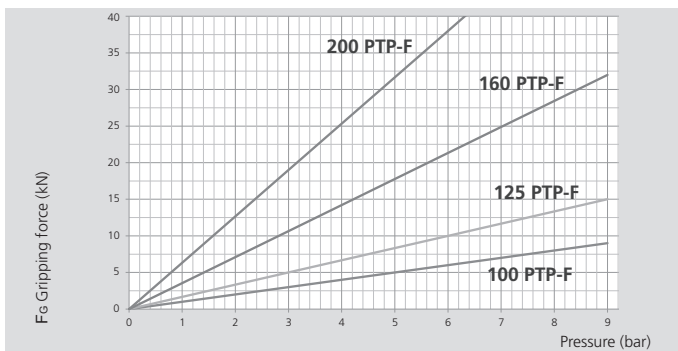
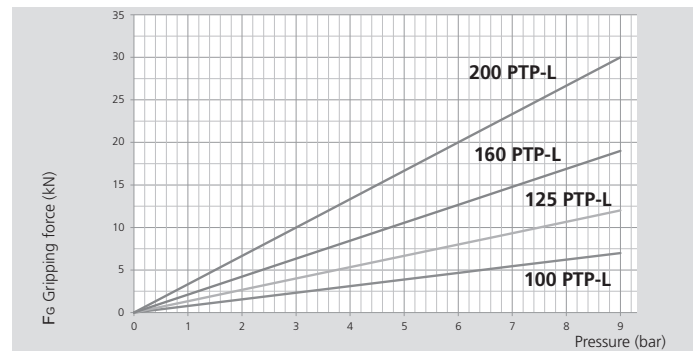
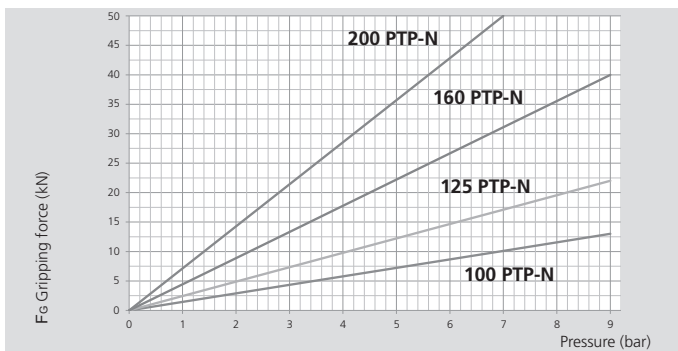

Technical data

Type	Id. No.	Stroke Type	Clamping force max. kN	Stroke / Jaw mm	Piston area cm ²	Operating pressure max. bar	Repeatability mm	Weight kg
100 PTP-N	77905211	Normal	13	2.6	45	9	0.01	5.5
100 PTP-L	77905311	Long	7	6	45	9	0.01	5.5
100 PTP-F	77905411	Fixed jaw	9	6	45	9	0.01	5.5
125 PTP-N	77905212	Normal	22	2.6	78	9	0.01	7
125 PTP-L	77905312	Long	12	6	78	9	0.01	7
125 PTP-F	77905412	Fixed jaw	15	6	78	9	0.01	7
160 PTP-N	77905217	Normal	40	3	128	9	0.01	13
160 PTP-L	77905317	Long	19	8.4	128	9	0.01	13
160 PTP-F	77905417	Fixed jaw	32	8.4	128	9	0.01	13
200 PTP-N	77905221	Normal	50	4.2	194	7	0.02	23
200 PTP-L	77905321	Long	30	10.2	194	9	0.02	23
200 PTP-F	77905421	Fixed jaw	38	10.2	194	6	0.02	23

Protected pneumatic twin vice

PTP-N

PTP-L

PTP-F

- Pneumatic version
- Pneumatic jaw stroke control valve

NORMAL STROKE

LONG STROKE

FIXED JAW

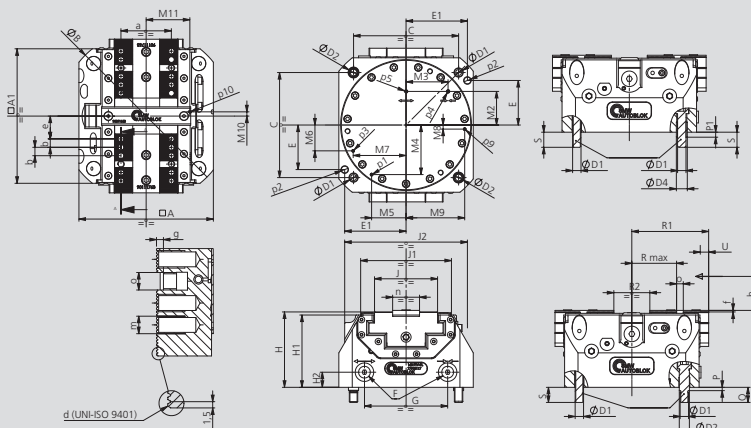

SMW-AUTOBLOK Type			PTP-N PTP-L PTP-F 100	PTP-N PTP-L PTP-F 125	PTP-N PTP-L PTP-F 160	PTP-N PTP-L PTP-F 200
	A	mm	100	125	160	200
	A1	mm	110	125	160	200
	B(Ø)	mm	136	162	205	255
	C	mm	80	100	125	160
	D1(Ø)	mm	M8	M8	M10	M12
	D2 (Øf7)	mm	10	10	12	14
	D4 (Øjs7)	mm	11	11	13	16
	E	mm	32	/	53	73
	E1	mm	45	/	73	92
	F	mm	M5	M5	G1/8"	G1/8"
	G	mm	59	59	99	127
	H	mm	75.5	80.5	89,7	97
	H1	mm	72	77	86	93
	H2	mm	15	17	18	18
	J	mm	47	47	75	94
	J1	mm	82	100	108	144
	J2	mm	100	121	146	166
	M2	mm	32	32	40	50
	M3	mm	29.5	29.5	50	65
	M4	mm	34,2	40.5	59	72.8
	M5	mm	27.7	38.5	41	52.9
	M6	mm	14,2	10.6	30.7	39.5
	M7	mm	41.1	54.5	62.9	80.9
	M8	mm	8.3	4.8	4.9	9.4
	M9	mm	42.7	55.3	69.8	89.5
	M10	mm	5	5	5	8
	M11	mm	34	34	52	60
	P	mm	4	4	4	5
	P1	mm	4	4	6	6
	Q	mm	15	15	18	20
min/max (long stroke)	R max	mm	25.6/31.6	25.6/31.6	44.8/53.2	54.5/64.7
min/max (normal stroke)	R max	mm	25.4/28	25.4/28	45/48	54.5/58.7
min/max (fixed jaw)	R max	mm	25.6/31.6	25.6/31.6	44.8/53.2	54.5/64.7
min/max (long stroke)	R1	mm	57.5/63.5	64.5/70.5	82.5/90.9	102.5/112.7
min/max (normal stroke)	R1	mm	57.4/60	64.4/67	82.5/85.5	102.8/107
min/max (fixed jaw)	R1	mm	57.5/63.5	64.5/70.5	82.5/90.9	102.5/112.7
min/max (long stroke)	R2	mm	20/32	20/32	26/42.8	30/50.4
min/max (normal stroke)	R2	mm	19.8/25	19.8/25	26/32	30.6/39
min/max (fixed jaw)	R2	mm	20/26	20/26	26/34.4	30/40.2
	S	mm	15	15	18	20
Long stroke	U	mm	6	6	8.4	10.2
Normal stroke	U	mm	2.6	2.6	3	4.2
Fixed jaw	U	mm	6	6	8.4	10.2
	a	mm	35	35	60	80
	b	mm	7	7	10	10
Serration	d	mm	1,5x60°	1,5x60°	1,5x60°	1,5x60°
min/max (long stroke) (fixed jaw)	e	mm	14.6/20.6	14.6/20.6	18.8/27.2	28.5/38.7
min/max (normal stroke)	e	mm	14.4/17	14.4/17	19/22	28.5/32.7
	f	mm	1.8	1.8	1.8	2
	g	mm	2.7	2.7	3.2	4
	h	mm	16	16	25	35
	m	mm	M6x10	M6x10	M8x12	M8x12
	n (g6)	mm	20	20	32	40
	o (H7)	mm	6	6	8	8
Lubrication fitting	p1	mm	M4	M4	M4	M4
	p2 (ØH7)	mm	/	/	8x14	8x14
Air stroke control or Air purge	p3	mm	M4	M4	M4	M4
Vice Closed	p4	mm	M4	M4	M4	M4
Vice Open	p5	mm	M4	M4	M4	M4
Air sensing connection	p9	mm	M4	M4	M4	M4
Air sensing outlet (under front plate)	p10	mm	M4	M4	M4	M4

PTH-N

NORMAL STROKE

PTH-L

LONG STROKE

Protected hydraulic twin vice

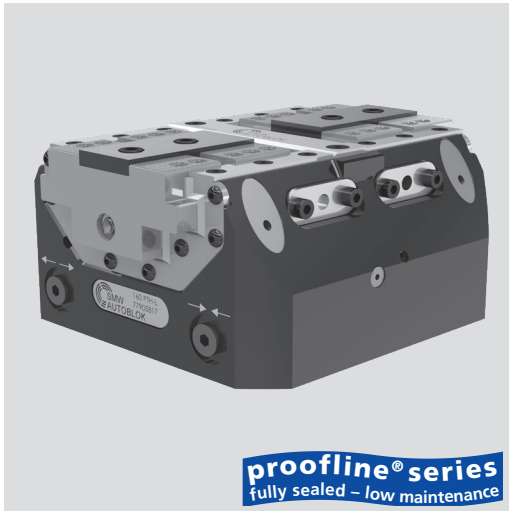

Application/customer benefits

- Protected against contamination of swarf and chips, fully sealed (proofline)
- Compact design
- Highest repeatability
- Highest rigidity
- Linear pressure adjustment

Technical features

- Housing and functional parts hardened for high precision and long life
- Air purge
- Ready for central grease lubrication
- Master jaws with both Tongue & Groove and fine serration 1.5 mm x 60°
- OD and ID clamping
- Pneumatic jaw stroke control valve (optional)
- Air sensing
- Stroke control via proximity switches (optional)

Standard equipment

Self-centering vice without top jaws
All bolts and centering bushings included

Actual gripping force diagrams

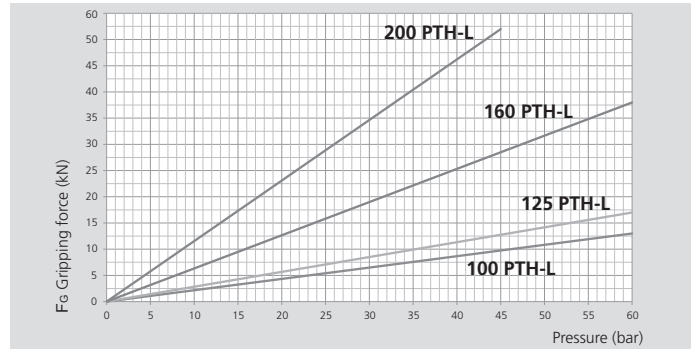
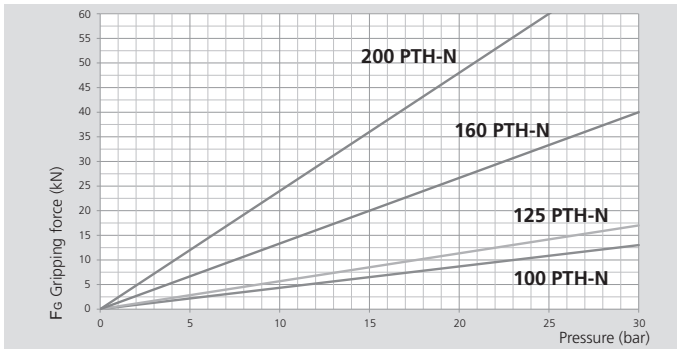

Technical data

Type	Id. No.	Stroke Type	Clamping force max. kN	Stroke / Jaw mm	Piston area cm ²	Operating pressure max. bar	Repeatability mm	Weight kg
100 PTH-N	77905711	Normal	13	2.6	15	30	0.01	6
100 PTH-L	77905811	Long	13	6	15	60	0.01	6
125 PTH-N	77905712	Fixed jaw	17	2.6	20	30	0.01	8
125 PTH-L	77905812	Normal	17	6	20	60	0.01	8
160 PTH-N	77905717	Long	40	3	45	30	0.01	15
160 PTH-L	77905817	Fixed jaw	38	8.4	45	60	0.01	15
200 PTH-N	77905721	Normal	60	4.2	68	25	0.02	25
200 PTH-L	77905821	Long	52	10.2	68	45	0.02	25

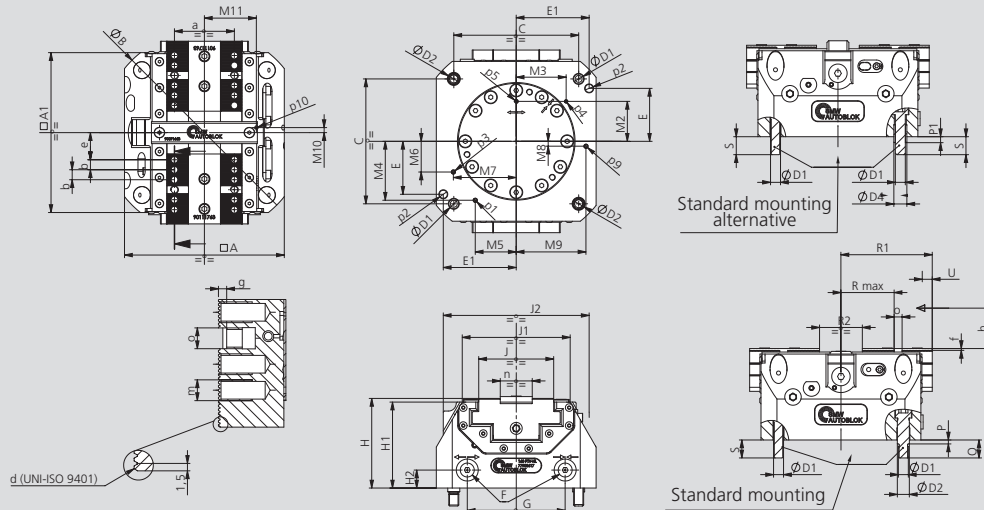

SMW-AUTOBLOK Type			PTH-N PTH-L 100	PTH-N PTH-L 125	PTH-N PTH-L 160	PTH-N PTH-L 200
A	mm		100	125	160	200
A1	mm		110	125	160	200
B(Ø)	mm		136	162	205	255
C	mm		80	100	125	160
D1(Ø)	mm		M8	M8	M10	M12
D2 (Øf7)	mm		10	10	12	14
D4 (Øjs7)	mm		11	11	13	16
E	mm		32	/	53	73
E1	mm		45	/	73	92
F	mm		G1/8"	G1/8"	G1/8"	G1/8"
G	mm		55	55	98	128
H	mm		75.5	80.5	89.7	97
H1	mm		72	77	86	93
H2	mm		15	17	18	18
J	mm		47	47	75	94
J1	mm		82	100	108	144
J2	mm		100	121	146	166
M2	mm		32	32	40	50
M3	mm		29.5	29.5	50	65
M4	mm		34.2	40.5	59	72.8
M5	mm		27.7	38.5	41	52.9
M6	mm		14.2	10.6	30.7	39.5
M7	mm		41.1	54.5	62.9	80.9
M8	mm		8.3	4.8	4.9	9.4
M9	mm		42.7	55.3	69.8	89.5
M10	mm		5	5	5	8
M11	mm		34	34	52	60
P	mm		4	4	4	5
P1	mm		4	4	6	6
Q	mm		15	15	18	20
min/max (long stroke)	R max	mm	25.6/31.6	25.6/31.6	44.8/53.2	54.5/64.7
min/max (normal stroke)	R max	mm	25.4/28	25.4/28	45/48	54.5/58.7
min/max (long stroke)	R1	mm	57.5/63.5	64.5/70.5	82.5/90.9	102.5/112.7
min/max (normal stroke)	R1	mm	57.4/60	64.4/67	82.5/85.5	102.8/107
min/max (long stroke)	R2	mm	20/32	20/32	26/42.8	30/50.4
min/max (normal stroke)	R2	mm	19.8/25	19.8/25	26/32	30.6/39
	S	mm	15	15	18	20
Long stroke	U	mm	6	6	8.4	10.2
Normal stroke	U	mm	2.6	2.6	3	4.2
	a	mm	35	35	60	80
	b	mm	7	7	10	10
Serration	d	mm	1.5x60°	1.5x60°	1.5x60°	1.5x60°
min/max (long stroke)	e	mm	14.6/20.6	14.6/20.6	18.8/27.2	28.5/38.7
min/max (normal stroke)	e	mm	14.4/17	14.4/17	19/22	28.5/32.7
	f	mm	1.8	1.8	1.8	2
	g	mm	2.7	2.7	3.2	4
	h	mm	16	16	25	35
	m	mm	M6 x 10	M6 x 10	M8 x 12	M8x12
	n (g6)	mm	20	20	32	40
	o (H7)	mm	6	6	8	8
Lubrication fitting	p1	mm	M4	M4	M5	M5
	p2 (ØH7)	mm	/	/	8x14	8x14
Air stroke control or Air purge	p3	mm	M4	M4	M5	M5
Vice Closed	p4	mm	M4	M4	M4	M4
Vice Open	p5	mm	M4	M4	M4	M4
Air sensing connection	p9	mm	M4	M4	M5	M5
Air sensing outlet (under front plate)	p10	mm	M4	M4	M4	M4

■ Mounting instruction

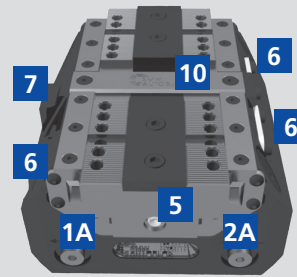
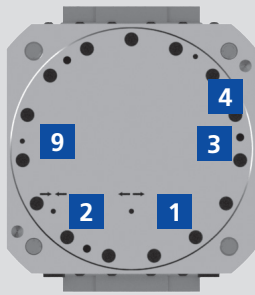

Solution 1 Standard

± 0,03 mm to clamping center

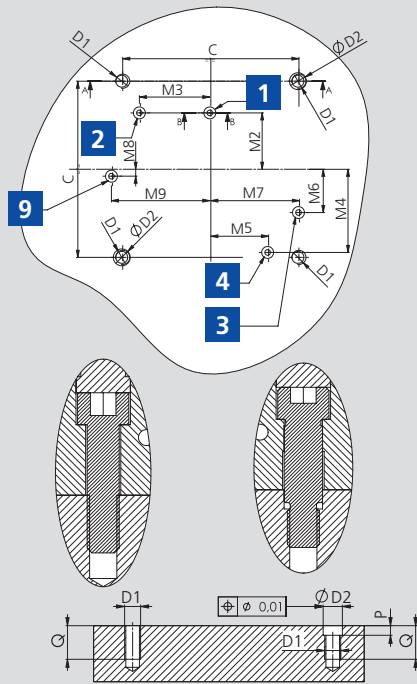

All bolts and centering bushings included

Solution 2 Standard

± 0,025 mm to clamping center

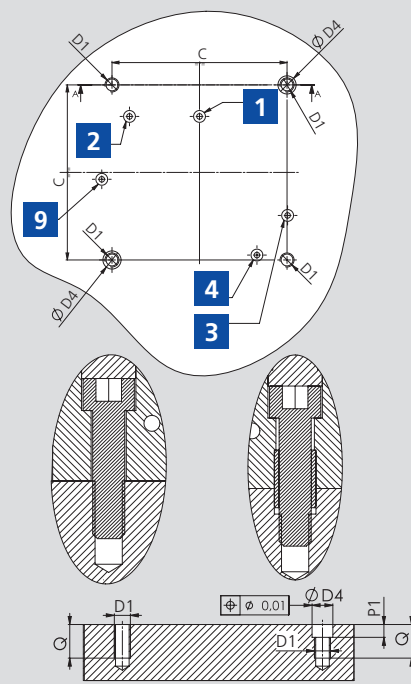

All bolts and centering bushings included

Feeding seats

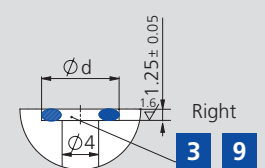
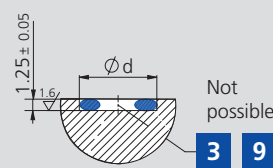
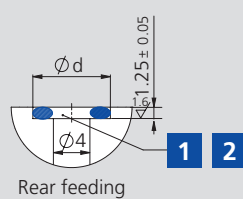
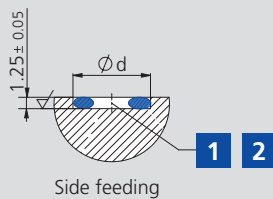

Functional Overview

1	Open-Rear feeding	1A	Open-Side feeding	5	Lubrication fitting	9	Air sensing connection (only bottom)
2	Closed-Rear feeding	2A	Closed-Side Feeding	6	Proximity switch seats	10	Air sensing outlet (under front plate)
3	Pneumatic stroke control or air purge*	4	Central lubrication	7	Pneumatic jaw stroke control valve		

* The air purge can be used only without the valve.

Type	C	D1	D2 H7	D4 H7	M2	M3	M4	M5	M6	M7	M8	M9	P	P1	Q	Ød	OR
PT 100	80	M8	10	11	32	29.5	34.2	27.7	14.2	41.1	7	43	6	6	18	8	OR2018
PT 125	100	M8	10	11	32	29.5	40.5	38.5	9.6	54.6	4.8	55.3	6	6	18	8	OR2018
PT 160	125	M10	12	13	40	50	59	41	30.7	62.9	4.9	69.8	6	7	21	8	OR2018
PT 200	160	M12	14	16	50	65	72.8	52.9	39.5	80.9	9.4	89.5	7	7	24	8,8	OR2021

- Normal stroke
- Central clamping

Application/customer benefits

- Protected against contamination of swarf and chips, fully sealed (proofline)
- Compact design
- Highest repeatability
- Highest rigidity
- Linear pressure adjustment

Technical features

- Housing and functional parts hardened for high precision and long life
- Air purge
- Ready for central grease lubrication
- Master jaws with both Tongue & Groove and fine serration 1.5 mm x 60°
- OD and ID clamping
- Air sensing
- Stroke control via proximity switches (optional)

Standard equipment

Self-centering vice without top jaws
All bolts and centering bushings included

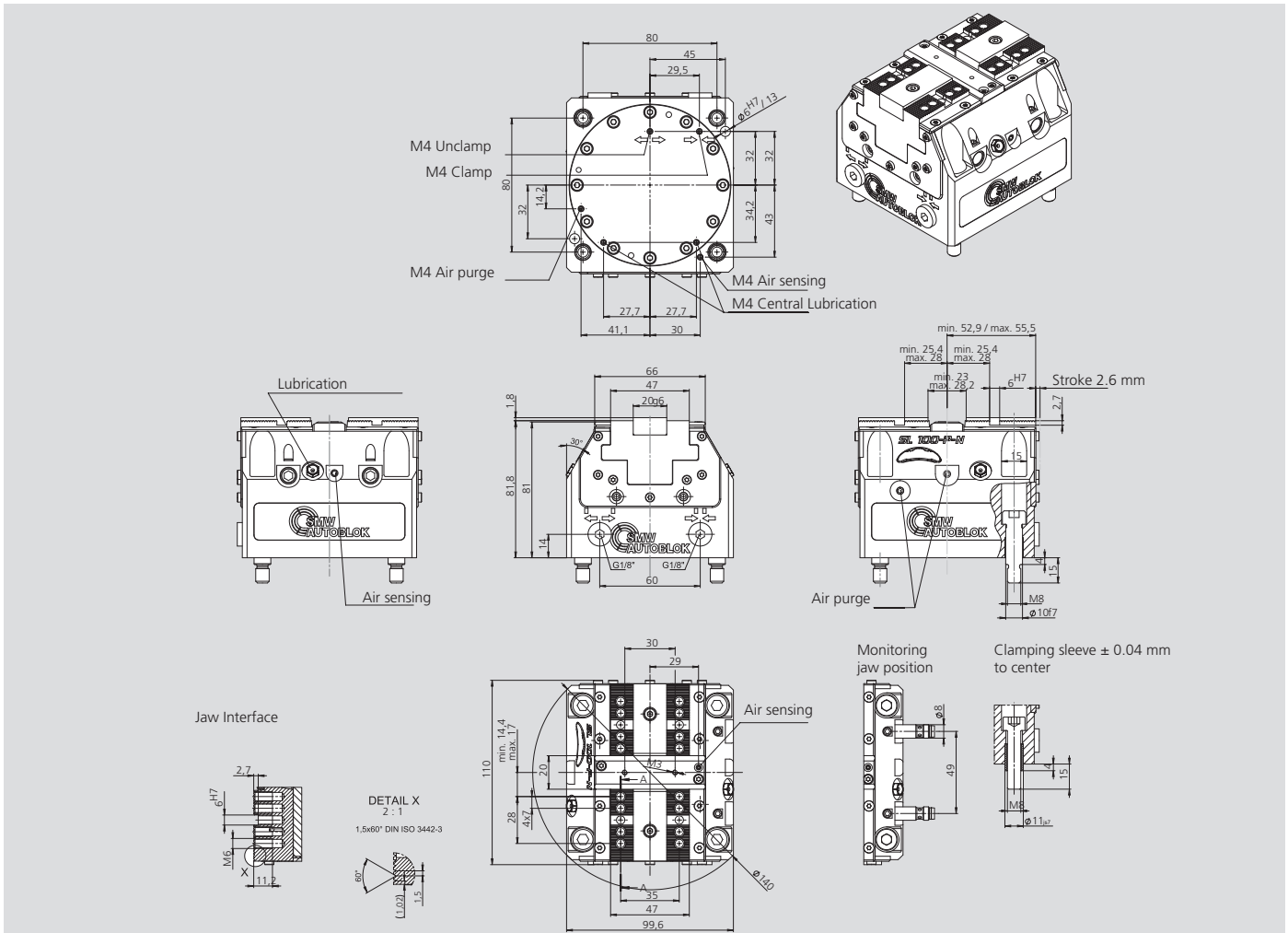

Order review

Type	Id. No.	Max. Clamping force kN	Stroke/Jaw mm	Max. Operating pressure bar	Repeatability mm	Weight kg
SL 100-P-N	461129	15	2.6	9	0.01	4.8

SL 160-P-N

Protected pneumatic twin vice

- Normal stroke
- Central clamping

Application/customer benefits

- Protected against contamination of swarf and chips, fully sealed (proofline)
- Compact design
- Highest repeatability
- Highest rigidity
- Linear pressure adjustment

Technical features

- Housing and functional parts hardened for high precision and long life
- Air purge
- Ready for central grease lubrication
- Master jaws with both Tongue & Groove and fine serration 1.5 mm x 60°
- OD and ID clamping
- Air sensing
- Stroke control via proximity switches (optional)

Standard equipment

- Self-centering vice without top jaws
- All bolts and centering bushings included



proofline® series
fully sealed – low maintenance

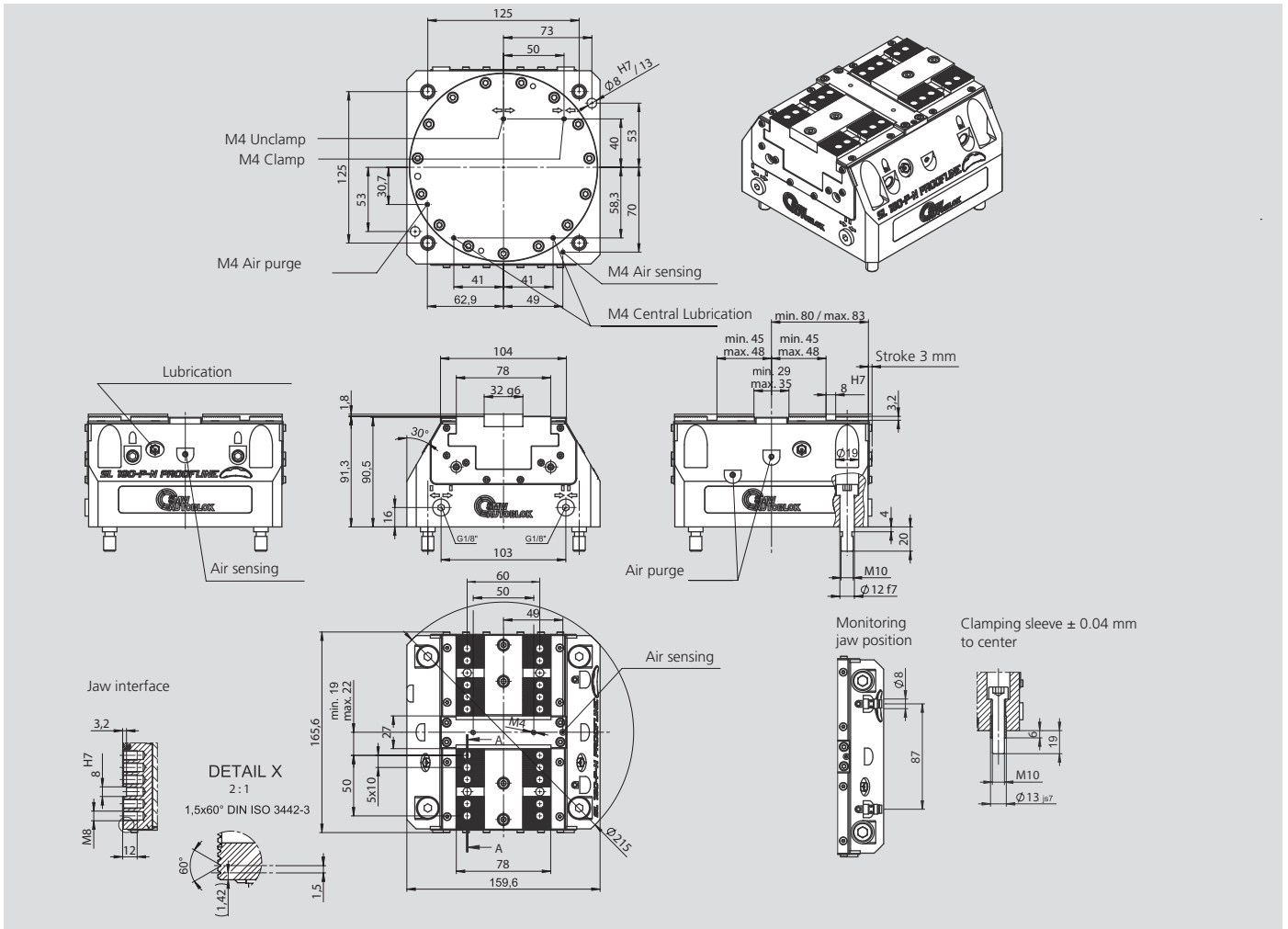

Order review

Type	Id. No.	Max. Clamping force kN	Stroke/Jaw mm	Max. Operating pressure bar	Repeatability mm	Weight kg
SL 160-P-N	461130	42	3	9	0.01	13

- Normal stroke
- Central clamping

Application/customer benefits

- Protected against contamination of swarf and chips, fully sealed (proofline)
- Compact design
- Highest repeatability
- Highest rigidity
- Linear pressure adjustment

Technical features

- Housing and functional parts hardened for high precision and long life
- Air purge
- Ready for central grease lubrication
- Master jaws with both Tongue & Groove and fine serration 1.5 mm x 60°
- OD and ID clamping
- Air sensing
- Stroke control via proximity switches (optional)

Standard equipment

Self-centering vice without top jaws
All bolts and centering bushings included



proofline® series
fully sealed – low maintenance

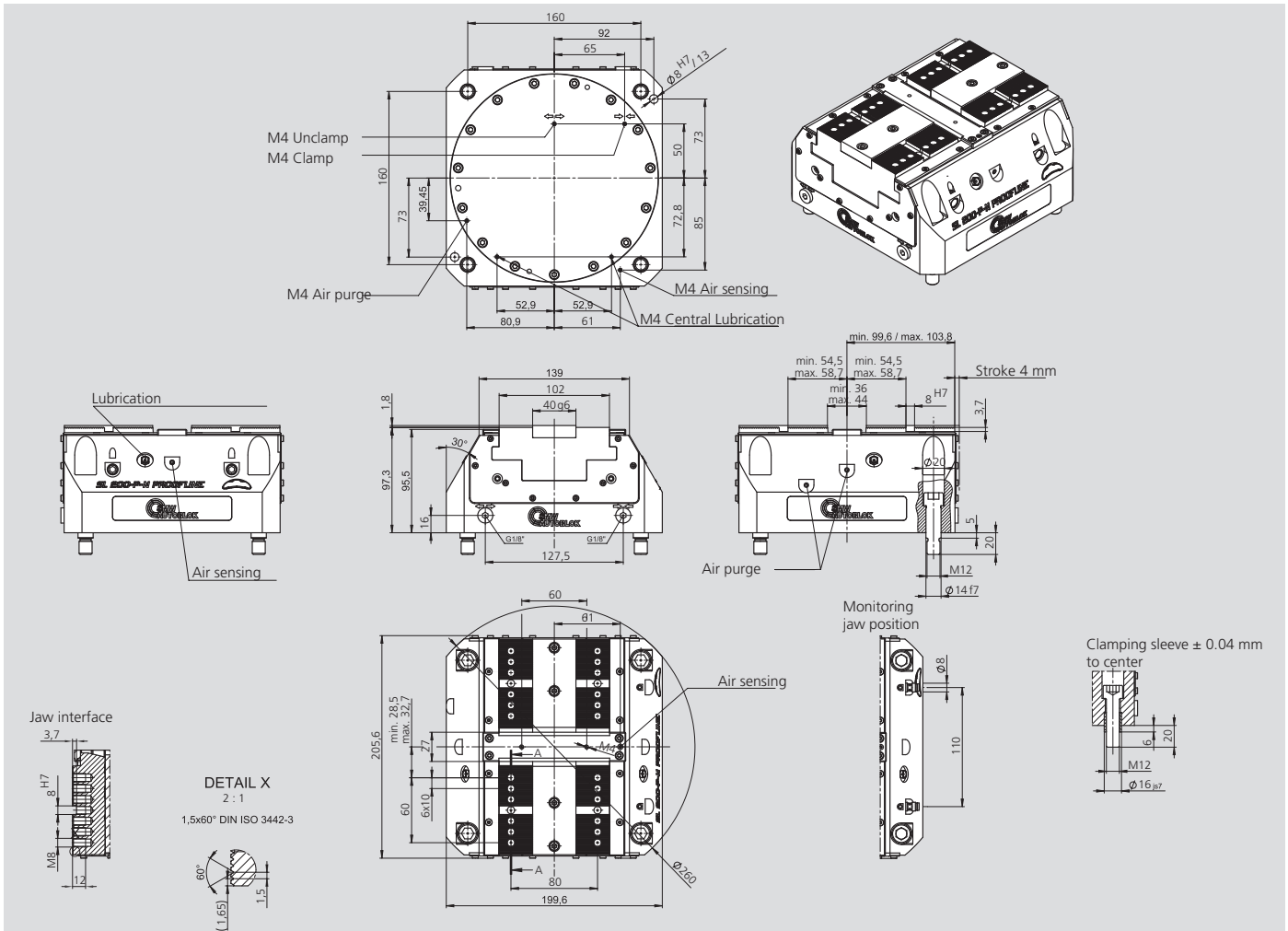

Order review

Type	Id. No.	Max. Clamping force kN	Stroke/Jaw mm	Max. Operating pressure bar	Repeatability mm	Weight kg
SL 200-P-N	461131	54	4	7	0.02	25.4

■ Mounting instruction

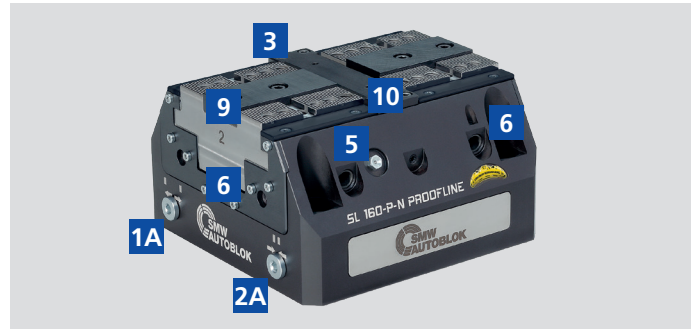

Solution 1 Standard

± 0,03 mm to clamping center

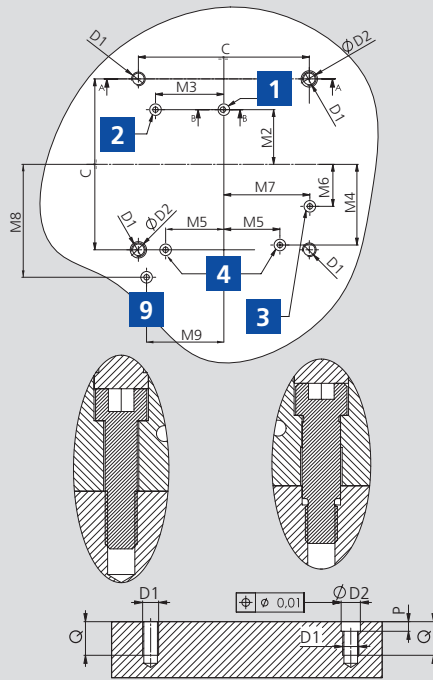

All bolts and centering bushings included

Solution 2 Standard

± 0,025 mm to clamping center

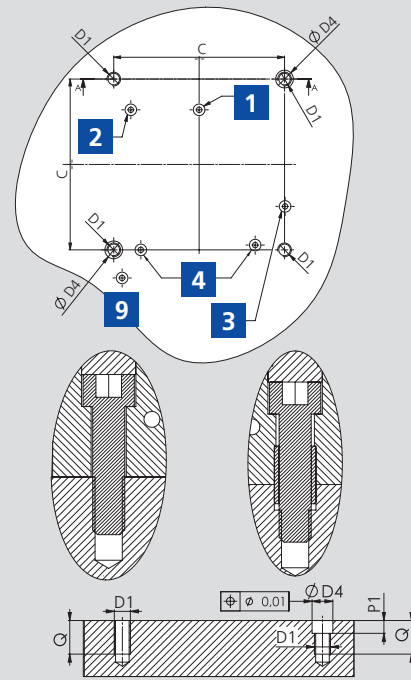

All bolts and centering bushings included

Feeding seats

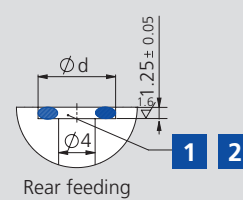
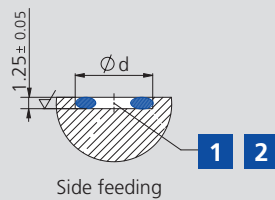

Functional Overview

1	Open-Rear feeding	1A	Open-Side feeding	5	Lubrication fitting	10	Air sensing outlet (under front plate)
2	Closed-Rear feeding	2A	Closed-Side Feeding	6	Proximity switch seats		
3	Air purge	4	Central lubrication	9	Air sensing connection		

Type	C	D1	D2 H7	D4 H7	M2	M3	M4	M5	M6	M7	M8	M9	P	P1	Q	Ød	OR
SL 100	80	M8	10	11	32	29.5	34.2	27.7	14.2	41.1	43	30	6	6	18	8	OR2018
SL 160	125	M10	12	13	40	50	58.3	41	30.7	62.9	70	49	6	7	21	8	OR2018
SL 200	160	M12	14	16	50	65	72.8	52.9	39.5	80.9	85	61	7	7	24	8,8	OR2021

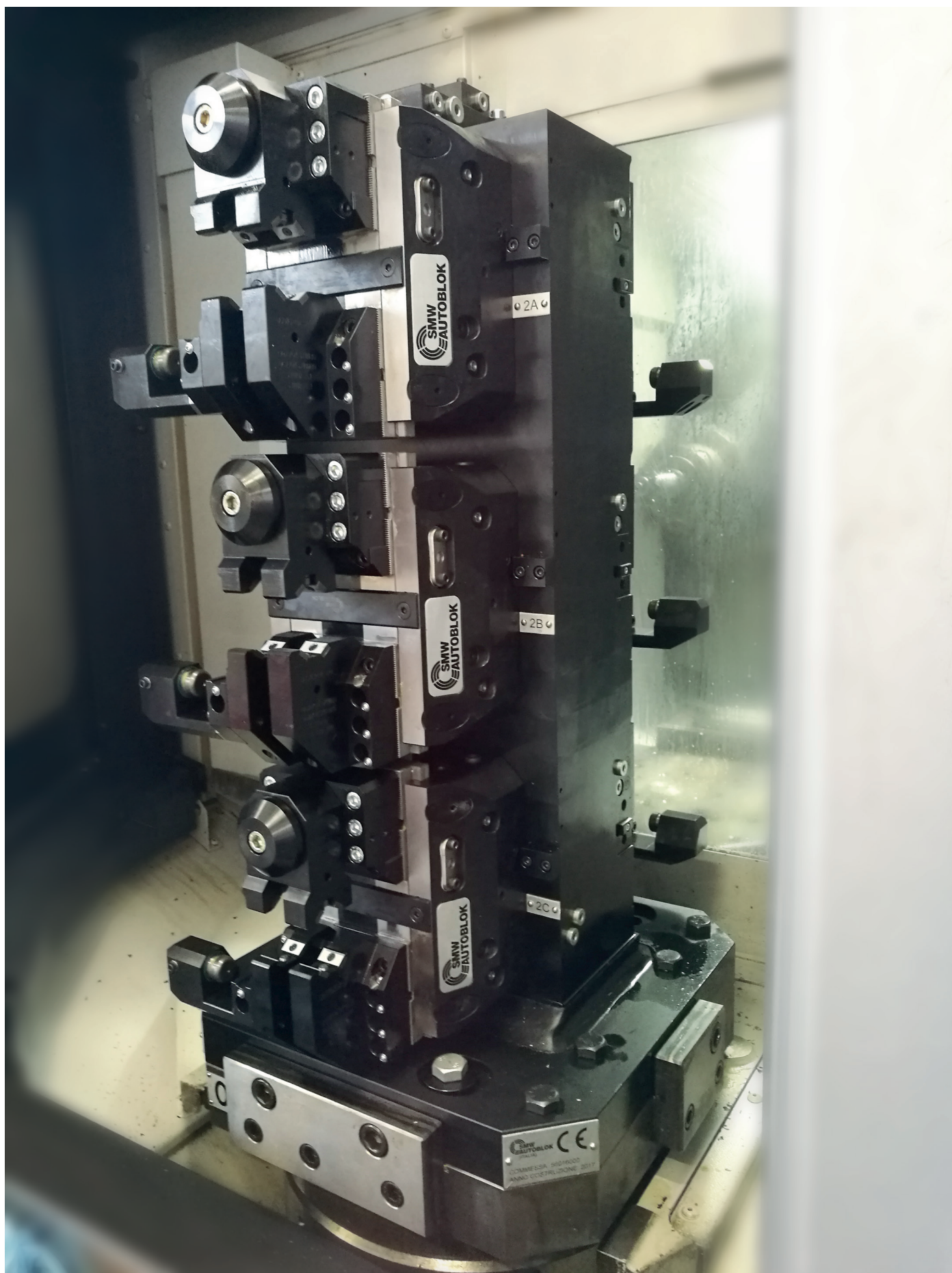

Soft blank top jaws, tongue & groove

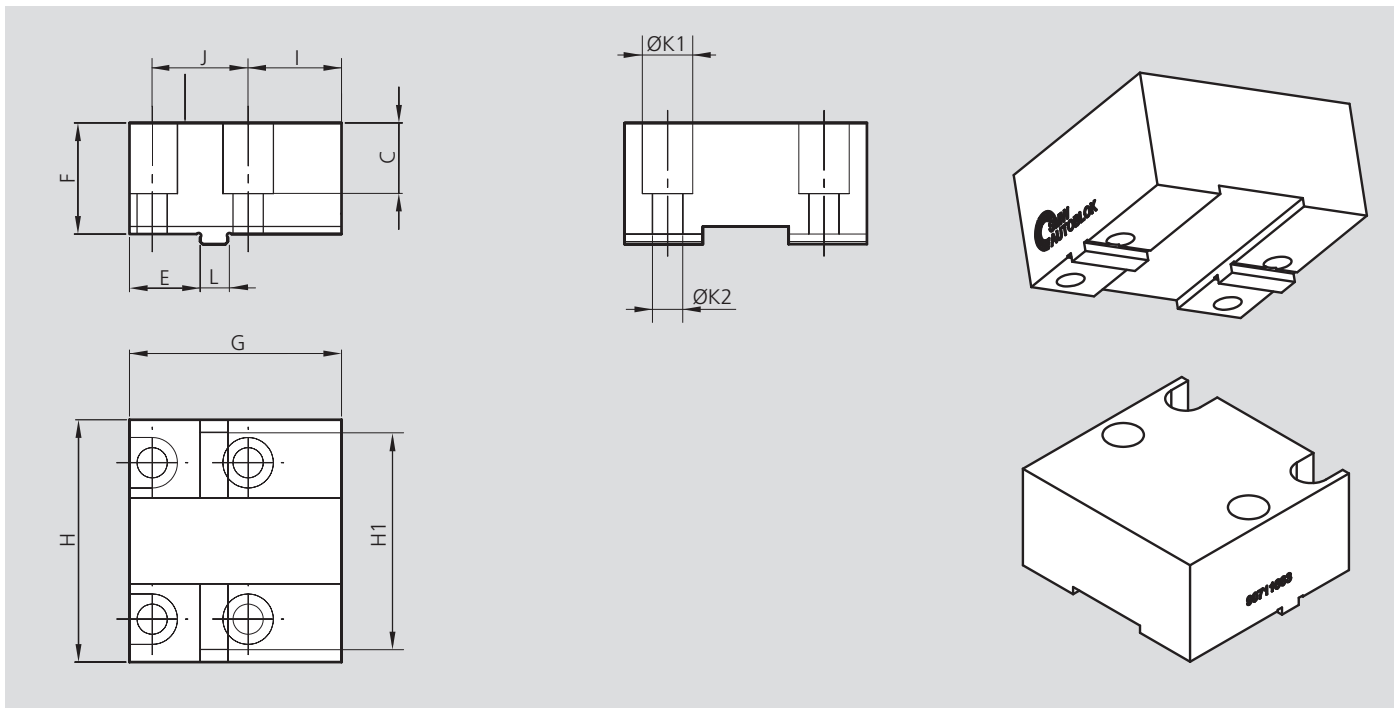

Type	Id. No.	C mm	E mm	F mm	G mm	H mm	H1 mm	I mm	J mm	K1 mm	K2 mm	L mm	Clamping range
100 TV / PT	90711063	20	18	27.5	49	54.5	45	21	21	11	7	6h7	0-70
125 STV-2 / PT	90711283	20	33	27.5	64	54.5	45	21	35	11	7	6h7	0-100
100 TV / PT / SL	90721063	40	18	47.5	49	54.5	45	21	21	11	7	6h7	0-70
125 STV-2 / PT	90721283	40	33	47.5	64	54.5	45	21	35	11	7	6h7	0-100
160 TV / PT / SL	90711663	27	27	37	79	79	74	38	30	14	9	8h7	0-120
180 STV-2 / PT	90711883	27	41	37	93	79	74	38	40	14	9	8h7	0-140
160 TV / PT / SL	90721663	66.5	27	76.5	79	79	74	38	30	14	9	8h7	0-120
180 STV-2 / PT	90721883	66.5	41	76.5	93	79	74	38	40	14	9	8h7	0-140
200 TV / PT / SL	90712063	37	37	47	98.5	109	92	47.5	40	14	9	8h7	0-150
200 TV / PT / SL	90722063	76.5	37	86.5	98.5	109	92	47.5	40	14	9	8h7	0-150
225 STV-2	90712283	37	52	47	113.5	109	92	47.5	50	14	9	8h7	0-180
225 STV-2	90722283	76.5	52	86.5	113.5	109	92	47.5	50	14	9	8h7	0-180
250 TV	90712563	31	59	47	120	124		44	48	18	11	10h7	0-170
250 TV	90722563	81.5	59	97.5	120	124		44	48	18	11	10h7	0-170
315 TV	90713163	42	54	57	150	160		75	60	20	13.5	12h7	on request
315 TV	90723163	87.5	54	102.5	150	160		75	60	20	13.5	12h7	on request

Consisting of 1 piece of jaw

Soft blank top jaws, tongue & groove, for STV-3

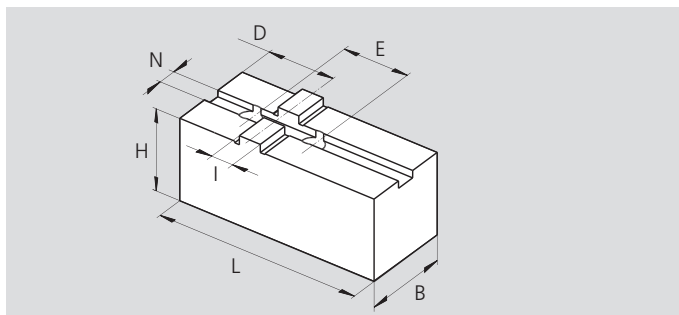

Type	Id. No.	B mm	H mm	L mm	N mm	D mm	E mm	I mm
180 STV-3	12041660	30	32	80	7.94	30	38.1	12.68
225 STV-3	12042060	35	37	100	7.94	35	44.4	12.68

Consisting of 1 piece of jaw

■ Fine serration 1.5 mm x 60°

Soft blank top jaws, fine serration 1.5 mm x 60°

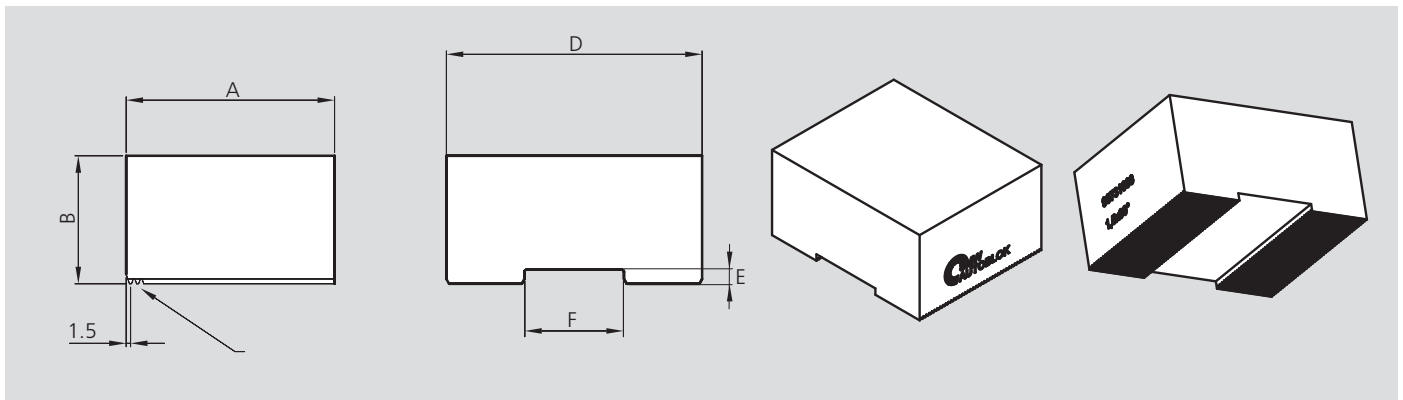

Type	Id. No.	A mm	B mm	D mm	E mm	F mm
100-125 STV / TV / PT / SL	90731063	42	29.5	54.5	2.5	20H8
100-125 STV / TV / PT / SL	90741063	47	49.5	54.5	2.5	20H8
160-180 STV / TV / PT / SL	90731663	66	39.5	79	3	32H8
160-180 STV / TV / PT / SL	90741663	76	79	79	3	32H8
200-225 STV / TV / PT / SL	90732063	87	49.5	109	4	40H8
200-225 STV / TV / PT / SL	90742063	87	89	109	4	40H8
250 TV	90732563	108	49.5	124	4	50H8
250 TV	90742563	108	99	124	4	50H8
315 TV	90733163	160	49.5	160	4	60H8
315 TV	90743163	160	105	160	4	60H8

Consisting of 1 piece of jaw

Soft blank top jaws, narrow, fine serration 1.5 mm x 60°

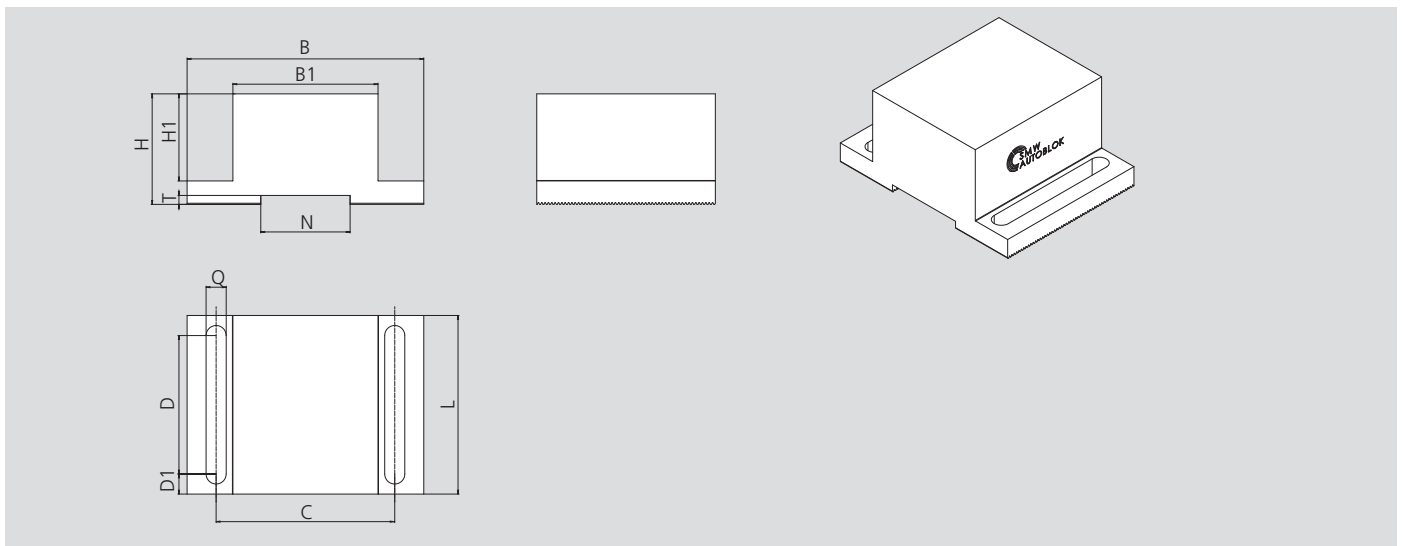

Type	Id. No.	B mm	B1 mm	C mm	D mm	D1 mm	H mm	H1 mm	L mm	N mm	Q mm	T mm
100-125 STV / TV / PT / SL	90751063	54.5	24	35	30	6	29.5	21.5	42	20H8	6.6	2.5
160-180 STV / TV / PT / SL	90751663	79	45	60	42	9	39.5	29	60	32H8	9	3
200-225 STV / TV / PT / SL	90752063	109	65	80	62	9	49.5	39	80	40H8	9	4
250 TV	90752563	124	72	90	62	14	49.5	33	90	50H8	11	4
315 TV	90753163	160	90	120	82	12	49.5	31.5	106	60H8	13.5	4

Consisting of 1 piece of jaw

SinterGrip jaws

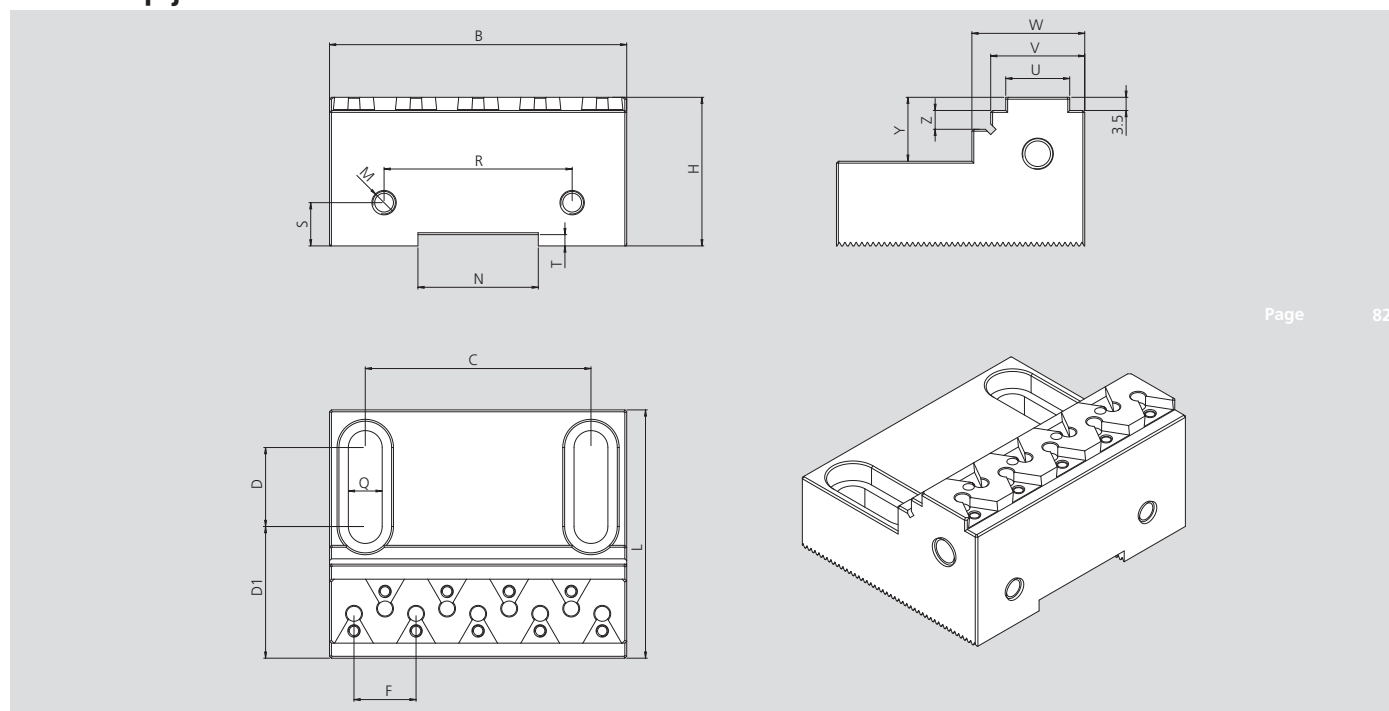

Type	Id. No.	B mm	C mm	D mm	D1 mm	F mm	H mm	L mm	M mm	N mm	Q mm	R mm	S mm	T mm	U mm	V mm	W mm	Y mm	Z mm	Inserts mm
100-125 (S)TV / PT / SL	58454119	54.5	35	7.4	28.3	16.5	29.5	42	M6	20 H8	6.6	35	11.5	2.5	14	22	27	17	5	5
160-180 (S)TV / PT / SL	58454129	79	60	21	35	16.5	39.5	66	M6	32 H8	9	50	11.5	3	17	25	30	17	5	9
200-225 (S)TV / PT / SL	58454139	109	80	21	39.5	18	49.5	87	M6	40 H8	9	70	11.5	4	17	25	30	27.5	7	11
250 TV	58454149	124	90	41	49.5	18	49.5	90	M6	50 H8	9	70	11.5	4	25	33	38	27.5	7	14
315 TV	58454159	160	120	66.5	66.75	18	49.5	160	M6	60 H8	13.5	70	11.5	4	30	38	43	27.5	7	16

SinterGrip jaws narrow

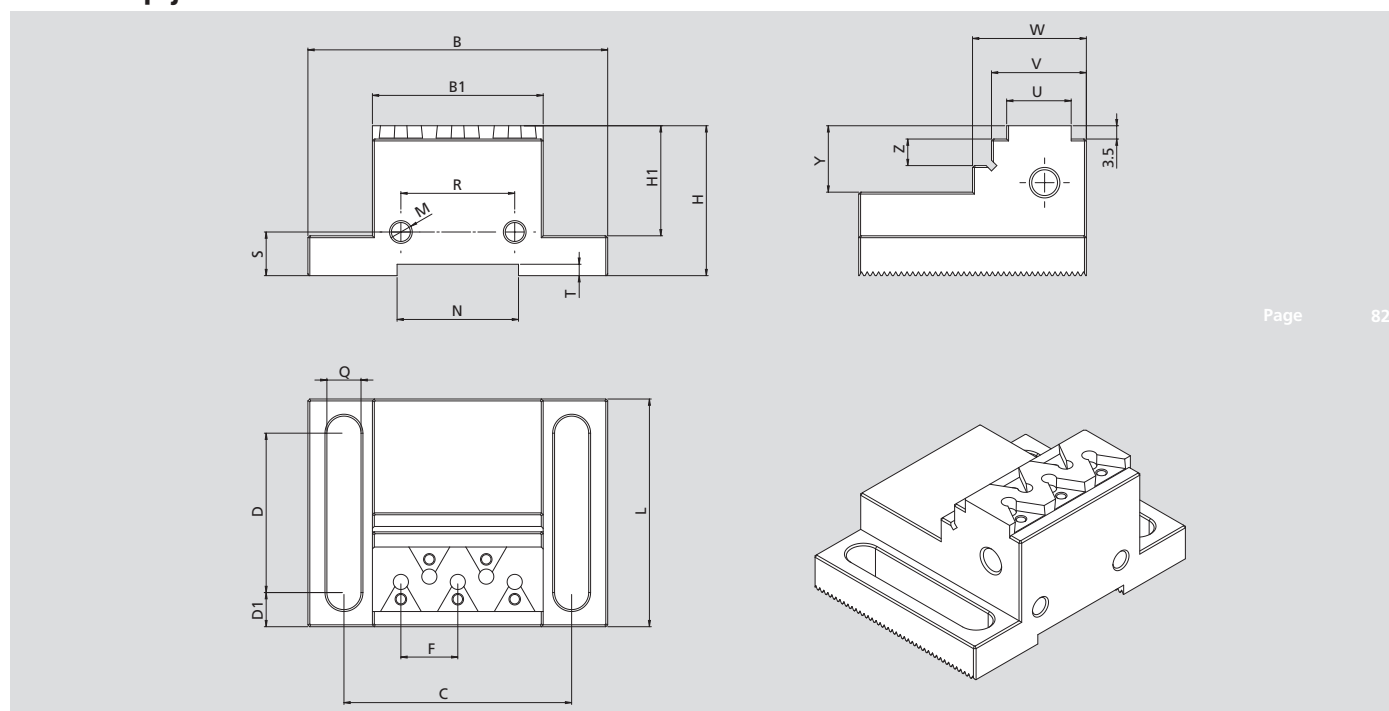

Type	Id. No.	B mm	B1 mm	C mm	D mm	D1 mm	F mm	H mm	H1 mm	L mm	M mm	N mm	Q mm	R mm	S mm	T mm	U mm	V mm	W mm	Y mm	Z mm	Inserts mm
160-180 (S)TV / PT / SL	58454229	79	45	60	42	9	15	39.5	29	60	M6	32 H8	9	30	11.5	3	17	25	30	17.5	7	5
200-225 (S)TV / PT / SL	58454239	109	65	80	62	9	16.5	49.5	39	80	M6	40 H8	9	40	11.5	4	17	25	30	17.5	7	7
250 TV	58454249	124	72	90	12	14	16.5	49.5	33	90	M6	50 H8	11	40	11.5	4	17	25	30	17.5	7	7
315 TV	58454259	160	90	120	82	12	15	49.5	31	106	M6	60 H8	13.5	40	11.5	4	17	25	30	17.5	7	11

All SinterGrip jaws: consisting of 1 piece of jaw, key T9 and mounting screws (depending on numbers of seats for SinterGrip), without SinterGrip inserts

■ Proximities for stroke control

Proximities for stroke control (optional)

2 sliding jaws:

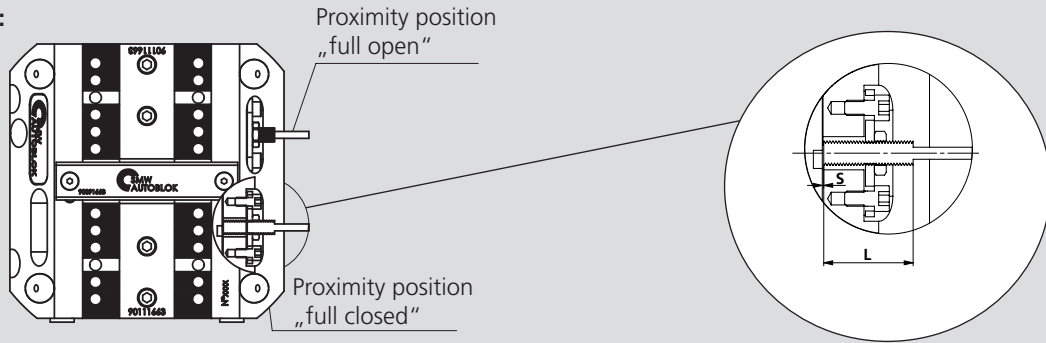

1 fixed jaw:

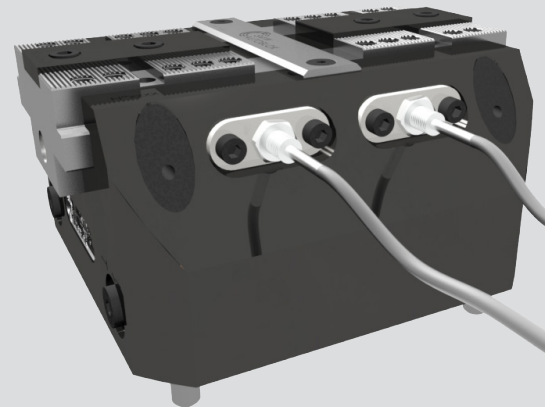
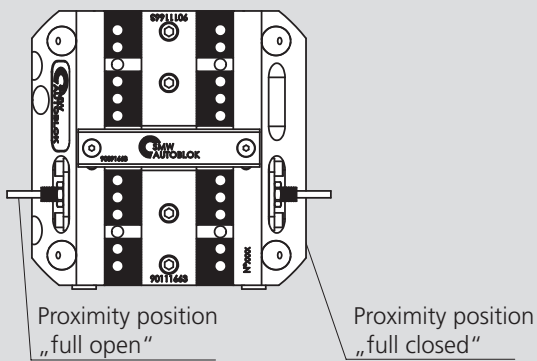

Twin vice Type	Thread	Sensor Balluff *	Omron alternative	Telemecanique alternative	S	L
100 TV	M5x0.5	BES516-3005-G-E4-C-PU02	E2EX1-B1	XS1N05PA310	0.5	20
160-200-250 TV	M8x1	BES516-324-G-E4-C-PU02	E2AS08KS02-WP-B12M	XS508B1PAL2	1	30
315 TV	M8x1	BESE08EF-PSC20B-BP02	E2AS08LS02-WP-B12M	XS508BLPAL2	1	40
125 STV-2	M5x0.5	BES516-3005-G-E4-C-PU02	E2EX1-B1	XS1N05PA310	0.5	20
180-225 STV-2	M8x1	BES516-324-G-E4-C-PU02	E2AS08KS02-WP-B12M	XS508B1PAL2	1	30
100-125 PT	M5x0.5	BES516-3005-G-E4-C-PU02	E2EX1-B1	XS1N05PA310	0.5	20
160-200 PT	M8x1	BES516-324-G-E4-C-PU02	E2AS08KS02-WP-B12M	XS508B1PAL2	1	30
100 / 160 SL	M8x1	BES516-324-549-C	-	-	-	40
200 SL	M8x1	BES516-324-SA33	-	-	-	53

* Recommended by SMW-AUTOBLOK

- Pneumatic jaw stroke control valve
- Safety valve SAB-1

Pneumatic jaw stroke control valve

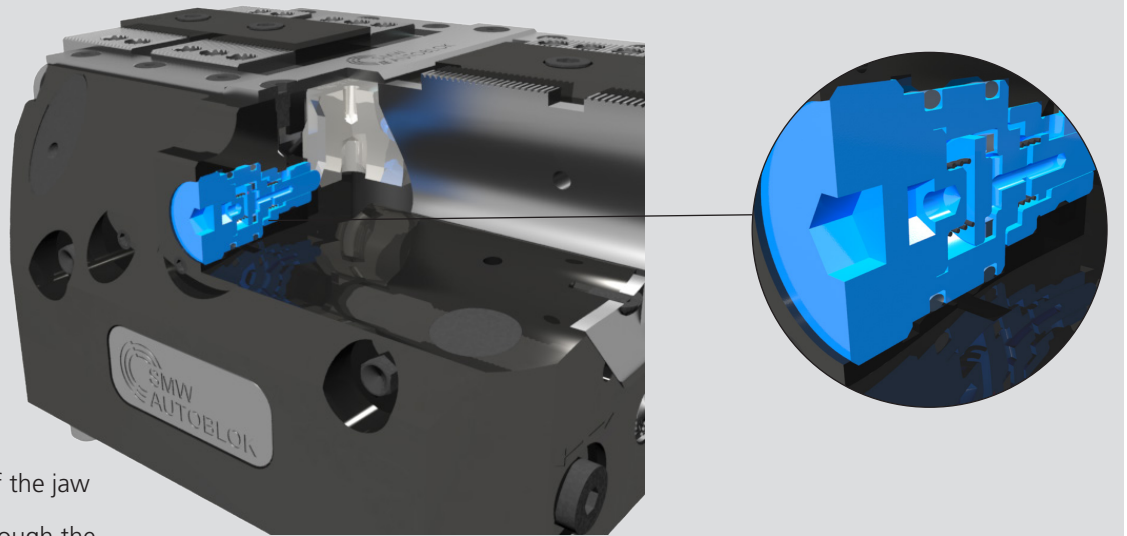

- For the monitoring of the jaw position
- Direct connection through the plate or the tombstone
- No cables needed
- Ideal for automation

Available for STV-2/STV-3 and PTP/PTH

Twin vice type	Id. No.
125 STV-2	90902283
180 STV-2	90902283
225 STV-2	90902283
180 STV-3	97901801
225 STV-3	97902204
100 PTP / PTH	90901163
125 PTP / PTH	90901763
160 PTP / PTH	90901763
200 PTP / PTH	90901763

Safety valve SAB-1

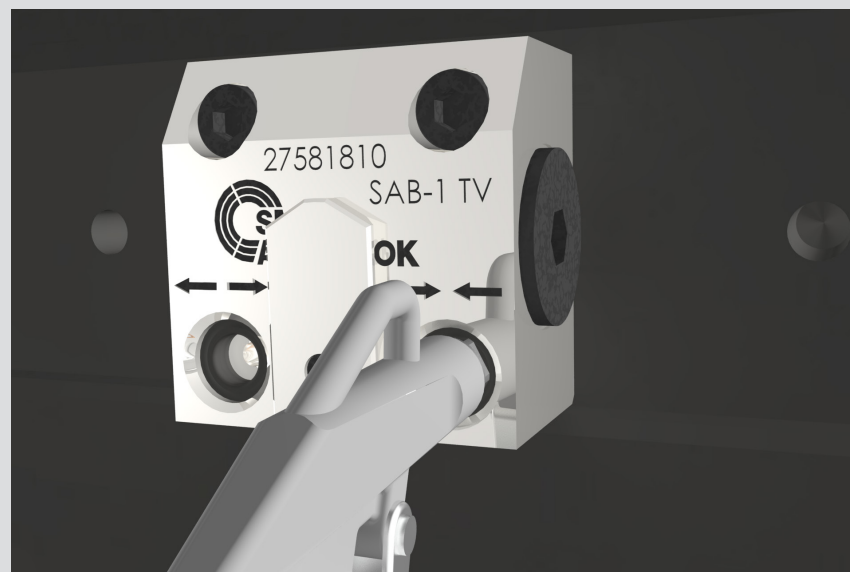

Safety valve SAB-1 to maintain air pressure during pallet transportation/storage and machining without feed

Available for STV-2/STV-3

Notes

A large area of horizontal stripes in two shades of blue, intended for writing notes. The stripes alternate between a medium blue and a lighter, pale blue color.

- Pneumatic jaw stroke control valve
- Safety valve SAB-1

Pneumatic jaw stroke control valve

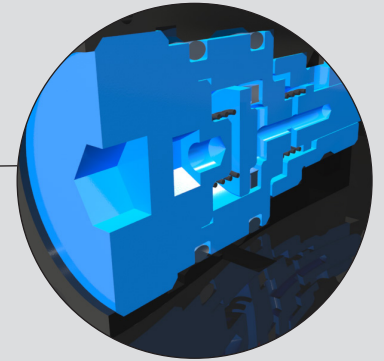
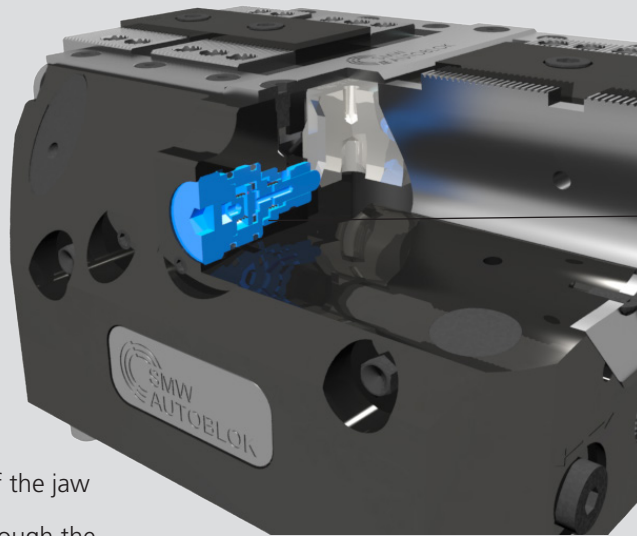

- For the monitoring of the jaw position
- Direct connection through the plate or the tombstone
- No cables needed
- Ideal for automation

Available for STV-2/STV-3 and PTP/PTH

Twin vice type	Id. No.
125 STV-2	90902283
180 STV-2	90902283
225 STV-2	90902283
180 STV-3	97901801
225 STV-3	97902204
100 PTP / PTH	90901163
125 PTP / PTH	90901763
160 PTP / PTH	90901763
200 PTP / PTH	90901763

Safety valve SAB-1

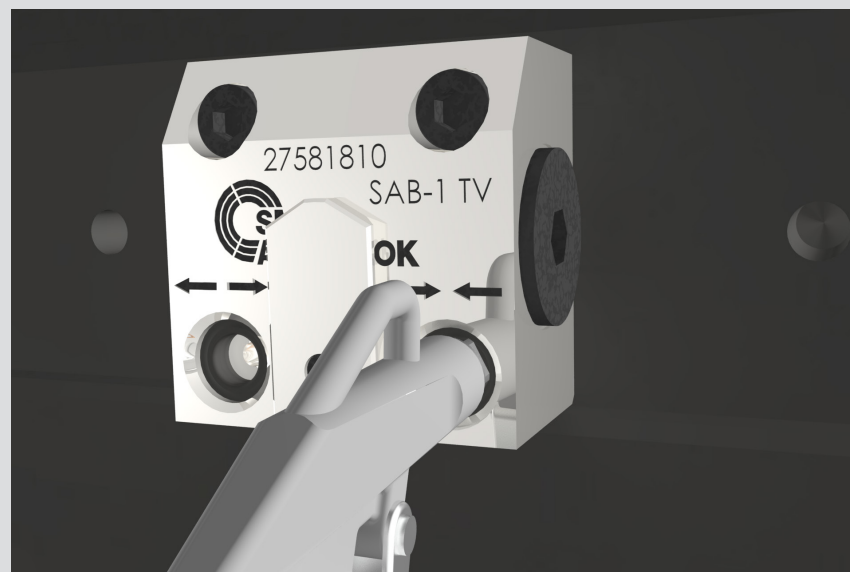

Safety valve SAB-1 to maintain air pressure during pallet transportation/storage and machining without feed

Available for STV-2/STV-3

Notes

A large area of horizontal stripes in two shades of blue, alternating between a medium blue and a light blue. This area is intended for writing notes.

**SMW-AUTOBLOK Spannsysteme GmbH**

Postfach 1151 • D-88070 Meckenbeuren
 Wiesentalstraße 28 • D-88074 Meckenbeuren
 Tel.: +49 (0) 7542 - 405 - 0

Vertrieb Inland > vertrieb@smw-autoblok.de
 Fax: +49 (0) 7542 - 3886
 Sales International > sales@smw-autoblok.de
 Fax: +49 (0) 7542 - 405 - 181

**U.S.A.**

SMW-AUTOBLOK Corporation
 285 Egidi Drive - Wheeling, IL 60090
 Tel. +1 847 - 215 - 0591
 Fax +1 847 - 215 - 0594

E-mail > autoblok@smwautoblok.com

**Japan**

SMW-AUTOBLOK Japan Inc.
 1-56 Hira, Nishi-Ku
 461-Nagoya
 Tel. +81 (0) 52 - 504 - 0203
 Fax +81 (0) 52 - 504 - 0205

E-mail > japan@smwautoblok.co.jp

**China**

SMW-AUTOBLOK (Shanghai) Work Holding Co.,Ltd.
 Building 6, No.72, JinWen Road, KongGang
 Industrial Zone, ZhuQiao Town, Pudong District
 201323, Shanghai P.R. China

Tel. +86 21 - 5810 - 6396
 Fax +86 21 - 5810 - 6395

E-mail > china@smwautoblok.cn

**Mexiko**

SMW-AUTOBLOK Mexico, S.A. de C.V.
 Pirineos No. 515-B, Nave 16
 Col. Industrial Benito Juarez
 Micro Parque Industrial Santiago
 Queretaro, Qro. C.P. 76130

Tel. +52 (442) 209 - 5118
 Fax +52 (442) 209 - 5121

E-mail > smwmex@smwautoblok.mx

**Indien**

SMW-AUTOBLOK Workholding Pvt. Ltd.,
 Plot No. 4, Weikfield Industrial Estate,
 Gat No. 1251, Sanaswadi, Tal - Shirur,
 Dist - Pune. 412 208

Tel. +91 2137 - 616 974
 Fax +91 2137 - 616 972

E-mail > info@smwautoblok.in

**Brasilien**

SYSTEC METALÚRGICA LTDA
 R. Luiz Brisque, 980
 13280-000 - Vinhedo - SP
 Tel. +55 (0) 193 886 - 6900
 Fax +55 (0) 193 886 - 6970

E-mail > systec@systecmetal.com.br

**Argentinien**

SMW-AUTOBLOK Argentina
 Rio Pilcomay 1121 - Bella Vista
 RA - 1661 Bella Vista Buenos Aires

Tel. +54 (0) 1146 - 660 603
 Fax +54 (0) 1146 - 660 603

E-mail > federicolojo@systecmetal.com.ar

**AUTOBLOK s.p.a.**

Via Duca D'Aosta n.24
 Fraz. Novaretto
 I-10040 Caprie - Torino
 Tel. +39 011 - 9638411
 Tel. +39 011 - 9632020

Fax +39 011 - 9632288

E-mail > info@smwautoblok.it

**Frankreich**

SMW-AUTOBLOK

17, Avenue des Frères Montgolfier - Z.I. Mi-Plaine
 F-69680 Chassieu

Tel. +33 (0) 4 - 727 - 918 18

Fax +33 (0) 4 - 727 - 918 19

E-mail > autoblok@smwautoblok.fr

**Großbritannien**

SMW-AUTOBLOK Telbrook Ltd.

7 Wilford Industrial Estate

Ruddington Lane, Wilford

GB-Nottingham, NG11 7EP

Tel. +44 (0) 115 - 982 1133

E-mail > info@smw-autoblok-telbrook.co.uk

**Spanien**

SMW-AUTOBLOK IBERICA, S.L.

Ursalto 10 - Nave 2, Pol. 27 - Mateo Gaina

20014 San Sebastián (Guipúzcoa) (Spain)

Tel.: +34 943 - 225 079

Fax: +34 943 - 225 074

E-mail > info@smwautoblok.es

**Russland**

SMW-AUTOBLOK Russia

B.Tulskaya str., 10, bld.3, off. 323,

115191 Moscow (Russia)

Tel. +7 495 -231-1011

Fax +7 495 -231-1011

E-mail > info@smw-autoblok.ru

**Taiwan**

AUTOBLOK Company Ltd.

NO.6, SHUYI RD., SOUTH DIST.,

TAICHUNG, TAIWAN

Tel. +886 4-226 10826

Fax +886 4-226 12109

E-mail > taiwan@smwautoblok.tw

**Tschechien / Slowakei**

SMW-AUTOBLOK s.r.o.

Merhautova 20

CZ - 613 00 BRNO

Tel. +420 513 034 157

Fax +420 513 034 158

E-mail > info@smw-autoblok.cz

**Schweden / Norwegen**

SMW-AUTOBLOK Scandinavia AB

Kasernvägen 2

SE - 281 35 Hässleholm

Tel. +46 (0) 761 420 111

E-mail > info@smw-autoblok.se

**Korea**

SMW-AUTOBLOK KOREA CO., LTD.

1108 ho, Baeksang Startower 1st,

65, Digital-ro 9-gil, Geumcheon-gu

Seoul, ROK-08511, Korea

Tel. +82 2 6267 9505

Fax +82 2 6267 9507

E-mail > info-korea@smw-autoblok.net