

# TBT Single Lip drills with indexable inserts WP-ELB Series 10

## Main Advantages:

1. **Versatility to use** on lathe, machining centers and deep hole machines.
1. **High efficiency** by specifically developed cutting edge geometry for ideal chip formation.
1. **Short downtime** resulting from quick exchange of wear parts
2. **Easy to use**, no sharpening, no length adjustment, easy inventory of wear parts.
3. **Long tool life** due to full coating, edge treatment and indexable design
4. **Quick availability** due to stocked wear parts and most common body sizes.



## Design:

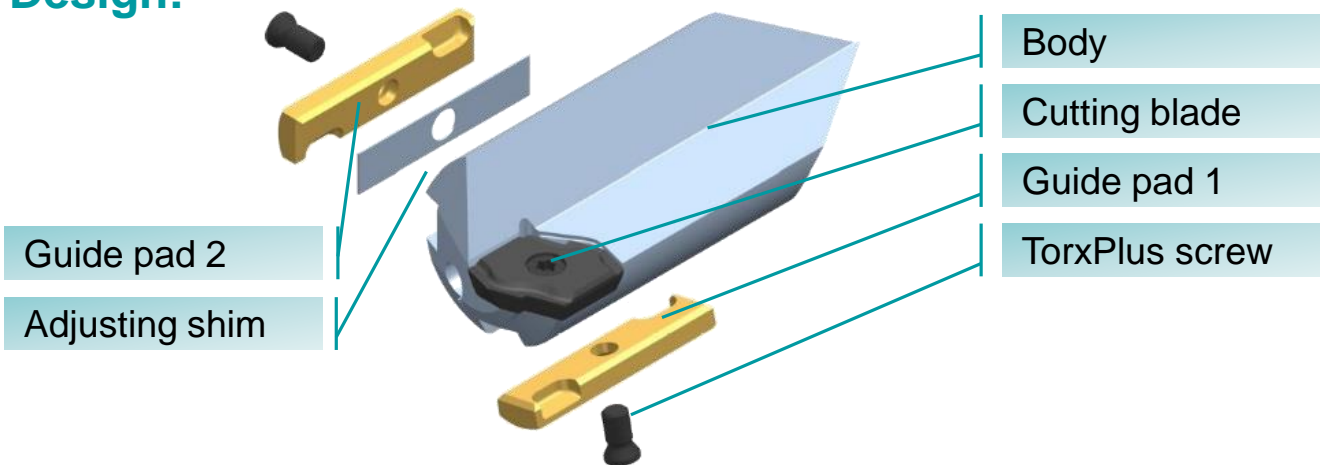

## Technical Information:

- Diameter range: 12.00 mm – 28.00 mm
- Cutting blade & guide pads fully coated
- Covering the whole diameter range with only 6 sizes of cutting blades.
- Tool body built in steps of 0.1 mm
- Available with long head and three additional guide
- Adjusting shim available to fine-tune diameter



# TBT Single Lip drills with indexable inserts WP-ELB Series 10

## Inquiries and delivery:

- Please state the required drill diameter, the overall length and the clamping element.
- You will receive your tools fully equipped and ready to use.
- Each tool comes with the suitable TorxPlus® key for the replacement of wear parts

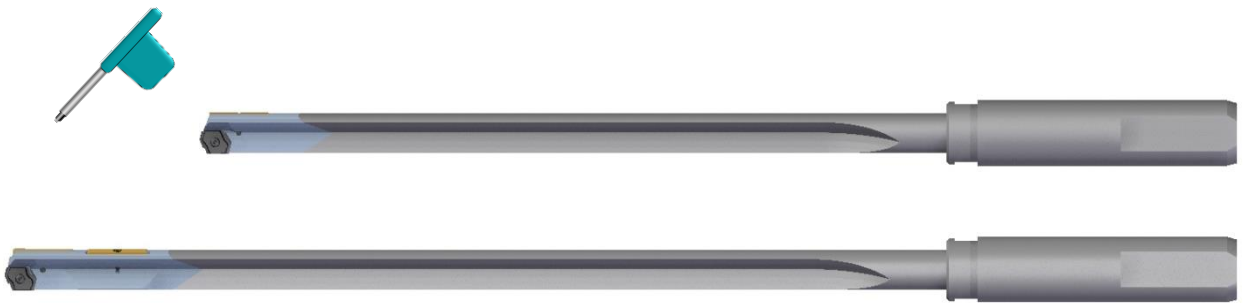

## Wear Parts overview:

Drill Ø		Cutting insert	Screw Torx Plus®	Guide pad	Screw Torx Plus®	Adjusting shim
von	bis					
12,00	13,99	<b>TSTS-CB2-00</b> TSTS000199	<b>6IP M2,2x4</b> TSTS000613	<b>TSTS-GC04A-P</b> TSTS000326	<b>6IP M2,2x4</b> TSTS000613	<b>TSTS-S04</b>
14,00	15,09	<b>TSTS-CB2-01</b> TSTS000094	<b>6IP M2,2x4,6</b> TSTS000614	<b>TSTS-GC05A-P</b> TSTS000091	<b>6IP M2,2x4,6</b> TSTS000633	<b>TSTS-S05</b>
15,10	17,39	<b>TSTS-CB2-02</b> TSTS000095	<b>7IP M2,5x5</b> TSTS000615		<b>7IP M2,5x5</b> TSTS000615	
17,40	19,79	<b>TSTS-CB2-05</b> TSTS000098		<b>7IP M3x6</b> TSTS000616	<b>TSTS-GC06-P</b> TSTS000016	<b>7IP M3x6</b> TSTS000616
19,80	23,89	<b>TSTS-CB2-07</b> TSTS000100				
23,90	28,09	<b>TSTS-CB2-08</b> TSTS000181				

Please direct your inquiry to:

e-mail: [tbtools@tbt.de](mailto:tbtools@tbt.de)

tel. +49-7123-976-352

fax: +49-7123-976-350